



vCam-5 User Handbook
(English Edition)
Version 1.1
P/N:4.04.000035



Table of Content

1. General Safety Instructions	1
1.1. Health and Safety	1
1.2. Worksite Safety	1
1.3. Equipment Safety	1
1.4. Batteries and Environmental Safety	1
1.4.1. Alkaline Batteries (Sondes, Light Kits or Locators)	1
2. Service & Support	2
2.1. Model and Serial Number Location	2
2.1.1. Control Module	2
2.1.2. Reels	2
2.1.3. Camera Heads	2
2.2. Firmware Revisions Location	3
2.3. Request for Service	3
2.4. Distributors and Service Centers	4
3. Introduction	5
3.1. The vCam-5 Inspection Camera System	5
3.2. Standard Equipment - Control Module	5
3.3. vCam-5 Control Module Overview	6
3.4. vCam Series Cable Reels Overview	9
3.4.1. Standard Equipment - Reels	9
3.4.2. Type-CP Standard Reel	9
3.4.3. Type-M2 Mini Reel	11
3.4.4. Termination Spring Kits	11
3.5. Camera Head Overview	12
4. Initial Control Module Setup	13
4.1. Initial Control Module Setup	13
4.1.1. Installing the Fuse	13
4.1.2. Charging the Internal Battery	13
4.1.3. The Interconnect Cable	14
4.1.4. About Control Module Settings	14
4.2. Navigating through the Setup Menu	14
4.2.1. Keyboard Keys used in the Setup Menu	15
4.2.2. Setting the Control Module Language	15
4.2.3. Setting the Default Storage	16
4.2.4. Setting the Distance Counter	17
4.2.5. Setting the Date, Time and Format	17
4.2.6. Setting the Sonde Frequency	18
4.2.7. WiFi Administration	19
4.2.8. Setting the Reel Type	19
4.2.9. Restore the Factory Default Settings	20
4.2.10. Update the Control Module Firmware	20
4.2.11. Update the Control Module Start Screen	23
4.2.12. The About Screen	24
4.2.13. Video Out	24
5. Video Recording and Picture Image Capture	25



5.1.	Overview	25
5.2.	Main File Menu	25
5.2.1.	File List Sub-Menu	26
5.2.2.	File Option Sub-Menu	27
5.2.3.	Media Select Sub-Menu	27
5.3.	Video Recording and Playback Controls	28
5.3.1.	Making a Video Recording	29
5.3.2.	JPEG Image Picture Capture	30
5.4.	Play Videos and View Pictures in the Control Module	30
5.4.1.	View Picture Image Files	31
5.4.2.	Renaming a Video or JPEG Image File	31
5.4.3.	Copy, Move or Delete Videos and Pictures	32
5.5.	File Format of SD Cards and USB Devices	33
5.6.	Troubleshooting Video Playback	33
5.7.	AVI Video Format	33
5.8.	Getting Codecs	33
5.9.	File Associations	34
5.10.	Other Media Players	34
6.	Features Available During Recording	36
6.1.	Voice Over	36
6.2.	Volume Control	36
6.3.	Display and Backlight Settings	37
6.4.	On-Screen Status Bar	37
6.5.	On-Screen Display (OSD Info)	37
6.6.	Camera LED Light Control	37
6.7.	Text Writer	38
6.7.1.	Introduction to the Text Writer	38
6.7.2.	Keyboard Function Keys of the Text Writer	38
6.7.3.	Text Writer Components	40
6.8.	JPEG Image Capture	40
6.9.	Digital Zoom	41
7.	WiFi and Ethernet	42
7.1.	WiFi Connection for Apps	42
7.2.	Ethernet Connection	42
7.2.1.	Connect by Ethernet	42
7.3.	Connect to a PC or Laptop by WiFi	46
7.3.1.	Connect the Control Module to a Laptop or PC	46
7.3.2.	Internet Explorer "Live View" Browser Interface	46
8.	Cable Reels	49
8.1.	Cable Reel Overview	49
8.1.1.	Pushrod Cable	49
8.1.2.	Using the Cable Reels	50
8.1.3.	Mounting the Control Module	50
8.1.4.	Remove the Control Module	52
8.1.5.	Deployment of the Pushrod Cable	52
9.	Camera Heads and Terminations	55
9.1.	Parts of the Camera Heads	55
9.1.1.	D25 Series Cameras with Manual Focus	55
9.1.2.	Camera Head Options	56
9.2.	Termination Parts	57
9.2.1.	Spring	57

9.2.2.	Coiled Cable Assembly	57
9.2.3.	Lanyard Set	58
9.2.4.	Termination Parts List	58
9.3.	Removing the Camera Head	59
9.4.	Removing the Termination Spring and Coiled Cable	61
9.5.	Installing the Coiled Cable and Termination Spring	62
9.5.1.	Pre-check the Termination Parts	62
9.5.2.	Pre-checking Steel Lanyards	62
9.5.3.	Pre-checking the Coiled Cable Assembly	62
9.5.4.	Pre-checking the Termination Spring	62
9.6.	Installing a Camera Head	63
9.6.1.	Install the Coiled Cable and Termination Spring	63
9.6.2.	Pre-checking the Camera Head before Installing	65
9.6.3.	Pre-checking for Picture and LED Control	65
9.6.4.	Pre-checking the Camera Base O-Ring	65
9.6.5.	Pre-checking the Camera Glass Lens and LED Cover	66
9.6.6.	Installing the Camera Head	66
10.	Camera Skids	68
10.1.	Camera Skids	68
10.2.	Skid Installations	68
10.2.1.	Standard Skid Installation	68
10.2.2.	Guide Skid Installation	69
10.2.3.	Removable Rubber Guard Skids	70
10.2.4.	Type-B Adjustable Skid	70
10.2.5.	Type-B Skid Installation	71
10.2.6.	Type-B Light Kit	71
10.2.7.	Type-B Light Kit Installation	72
11.	Locating Sondes and Pushrod	73
11.1.	Introduction	73
11.2.	Applying a Locate Signal onto the Pushrod	73
11.3.	The vLocCam2 Sonde and Camera Locator	74
11.4.	Locating with the vLocCam2	75
11.5.	VM-540 Sonde and Camera Locator	77
12.	Accessories	80
12.1.	Skid Range	80
12.2.	Accessories	81
12.3.	Camera and Sonde Locators	82
12.4.	Sondes	82
13.	Troubleshooting	83

1. General Safety Instructions

1.1 Health and Safety

This equipment is primarily used for the inspection of sewer pipes by professionals operating in the sewer and plumbing industry. Maintained by professionals familiar with the health risks of maintaining equipment that has been in a sewer.

Such professionals will be protected by their own company's recommendations and work practices. If for any reason they are not, or are not familiar with such practices, please check our website or email sales@vxmt.com for a copy of the Health and Safety Document used by Vivax-Metrotech for employees involved in the demonstration, maintenance and handling of sewer camera systems.

- Keep all electrical connections dry and off the ground.
- Be aware of your surroundings at all times. Cone off open manholes and follow traffic control regulations.
- Use personal protection such as eyewear, rubber gloves and non-skid safety shoes.
- **Do not** use the control module as a handle to move the reel. Remove the control module or use the steel handle that is part of the reel's frame.

1.2 Worksite Safety

- Use your company's, or other applicable safety code and rules when using this equipment.
- **Do not** use this equipment in explosive areas – such as in the presence of flammable liquids, gases, and heavy dust.

1.3 Equipment Safety

- **Do not** open the enclosures (housings) of the control module or camera heads.
- Opening the housings or the control module or camera head will void any warranty.
- Use only the leads supplied with the control module for AC or DC operation and charging.

1.4. Batteries and Environmental Safety

Vivax-Metrotech products use four types of batteries:

- Alkaline batteries
- Ni-MH (Nickel Metal Hydride) – rechargeable
- Lithium Ion batteries – rechargeable
- Lithium metal batteries – (small non-rechargeable button cells for “clock” applications)

1.4.1. Alkaline Batteries (Sondes, Light Kits or Locators)

- When replacing the alkaline batteries – use only the size and type specified – **do not** mix battery types (rechargeable and alkaline).
- **Do not** mix partially discharged and fully charged cells in the same battery pack – do not mix old with new.
- Never attempt to charge alkaline batteries.

2. Service & Support

2.1 Model and Serial Number Location

Always quote your camera system's model number, serial number and software revision number when requesting product support.

2.1.1. Control Module

The vCam-5 Control Module model number and serial numbers are found on the back of the unit.



1	Serial Number
---	---------------

2.1.1. Reels

The serial numbers for the vCam series reels are found on the label affixed to the frame located at the center of the frame on the opposite of the locking and friction brakes.

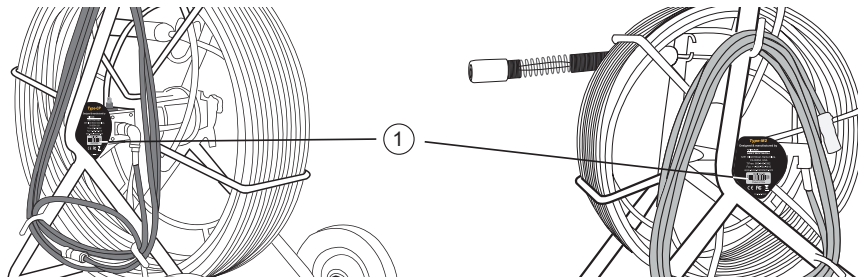

Type-CP Reel

Type-M2 Reel

1	Serial Number
---	---------------

2.1.3. Camera Heads

The camera head models are a combination of the outside diameter of the camera head (less skid) and the type of reel termination it fits on.

- D25-M is 25mm / 1" in diameter and used on the Type-M or Type-M2 reel.
- D34-C is 34mm / 1.3" in diameter and used on the Type-C or Type-CP reel.
- D34-M is 34mm / 1.3" in diameter and used on the Type-M or Type-M2 reel.
- D46-CP is 46mm / 1.5" in diameter and used on the Type-C or Type-CP reel.

2 Service & Support

The camera skid must be removed to view the serial number of the camera head.



The serial number for the D25-M camera is etched into the camera housing across the top of the camera.

The serial numbers for the D34-C, D34-M and D46-CP are etched into the camera base across the length of the camera.

1	Serial Number
---	---------------

2.2. Firmware Revisions Location

The "About" screen found in the setup menu shows the control module's firmware (software) version and release date.

There are two types of firmware:

- DVR – for DVR recorder
- MCU – for microprocessor

1. Press the **F10 Menu** key twice on the control module keyboard to bring up the **Setup** menu.
2. Use the **down ↓ arrow** key to scroll down to the **About** selection.
3. Press **Enter** or use the **right → arrow** key to show the firmware version information.

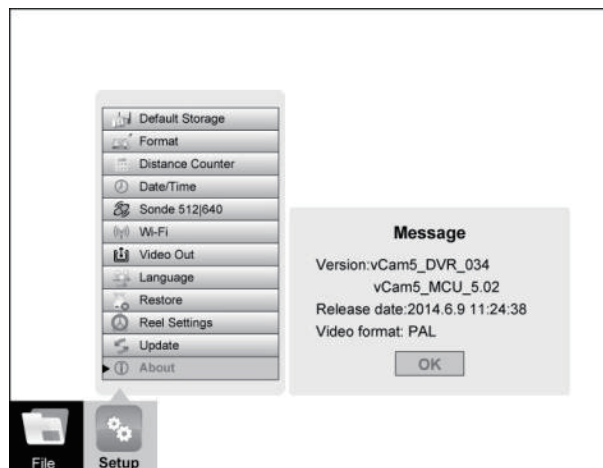

4. Press the **left ← arrow** key or **ESC** key three times to return to the **Setup** menu.

2.3. Request for Service

In the event that any of the system components need servicing the more concise information provided will result in a quicker turnaround time. On our website you can fill out a "Service Center Request" form, print it and include it with the unit when shipping. If the unit must be returned, package it well and ship by a traceable method.

2.4. Distributors and Service Centers

World Headquarters, United State of America	China
<p>Vivax-Metrotech Corporation 3251 Olcott Street, Santa Clara, CA 95054, USA Website : www.vivax-metrotech.com</p> <p>Sales & Sales Support: T/Free : 800-446-3392 Tel : +1-408-734-1400 Fax : +1-408-734-1415 Email : sales@vxmt.com</p> <p>Service & Repairs: T/Free : 800-638-7682 Tel : +1-408-962-9990 Fax : +1-408-734-1799 Email : service@vxmt.com</p>	<p>Leidi Utility Supply (Shanghai) Ltd. No. 780, Tianshan Rd, Shanghai, China 200051</p> <p>T/Free : 4008-206-719 Tel : +86-21-5235-3001 Fax : +86-21-5235-8365 Website : www.leidi.cn Email : info@leidi.cn</p>
	Europe
	<p>Megger Seba Dynatronic Mess-und Ortungstechnik GmbH Dr.-Herbert-lann-Str. 6, 96148 Baunach, Germany</p> <p>Tel : +49-9544-680 Fax : +49-9544-2273 Website : www.megger.com Email : service@megger.com</p>
	France
	<p>Vivax-Metrotech SAS Technoparc - 1 allée du Moulin Berger, 69130 Ecully, France</p> <p>Tel : +33(0)4 72 53 03 03 Fax : +33(0)4 72 53 03 13 Website : www.vivax-metrotech.com Email : salesfrance@vxmt.com</p>
	United Kingdom
	<p>Vivax-Metrotech Ltd. Unit 18-19, Woodside Road, South Marston Industrial Estate, Swindon, SN3 4WA, UK</p> <p>Free Phone : 0800 0281811 Tel : +44(0)1793 822679 Website : www.vivax-metrotech.com Email : salesUK@vxmt.com</p>
Australasia	
<p>Vivax-Metrotech AUS Unit 1, 176 South Creek Road, Cromer NSW 2099, Australia</p> <p>Tel : +61-2-9972-9244 Fax : +61-2-9972-9433 Website : www.vivax-metrotech.com Email : sales@vxmtaus.com service@vxmtaus.com</p>	
Canada	
<p>Vivax Canada Inc. 41 Courtland Ave Unit 6, Vaughan, ON L4K 3T3, Canada</p> <p>Tel : +1-289-846-3010 Fax : +1-905-752-0214 Website : www.vivax-metrotech.com Email : CanadianSales@vxmt.com</p>	
Central/South America and the Caribbean	
<p>Ventas para América Latina 3251 Olcott Street, Santa Clara, CA 95054, USA Website : www.vivax-metrotech.com</p> <p>T/Free : 800-624-6210 Tel : +1-408-734-1400 Fax : +1-408-743-5597 Email : VentasparaAmericaLatina@vxmt.com</p>	

3. Introduction

3.1. The vCam-5 Inspection Camera System

The vCam-5 Inspection System consist of three major components: vCam-5 Control Module, vCam Series Reels, and Camera Heads.

3.2. Standard Equipment - Control Module



Along with the vCam-5 Control Module, the following accessories are included:



1.	Quick Guide	With brief basic instructions.
2.	CD ROM Disc	With manual and video codec.
3.	Soft Carry Pouch	To hold all the accessories.
4.	2mm Hex Key	For use with the D25-M, D34-M and D34-C camera skids.
5.	Flat Head Screwdriver	For use with the D46-CP camera skids.
6.	USB Thumb Drive	For storing transferred videos and pictures.
7.	10 Amp, 250 Volt Fuse	Two fuses are included. One needed to allow the internal battery to charge and one spare.
8.	User Handbook	With full operating instructions.
9.	12V DC Power Cable	To power and charge the unit from a vehicle or 12V DC source.
10.	AC Power Cable	For charging and powering the control module.
11.	Cross Talk Ethernet Cable	For direct connection to a computer.
12.	Camera Removal Tool	To remove the camera head and termination spring.
13.	SD Card	To store transferred videos and pictures.

3.3. vCam-5 Control Module Overview

The vCam-5 control module allows for the viewing, recording and playback of Audio Video Interleave (AVI) format video as well as image capturing of Joint Photographic Experts Group (JPEG) pictures. Audio and text commentary can be added to the videos and text commentary can be added to the captured pictures.

The time stamping of current time, date and distance of pushrod deployed can be added to both video and pictures.

The following describes the features and use of the control module:

Control Module Front View



Feature

1.	Carry handle
2.	Recording, snapshot, zoom and video playback controls
3.	8" daylight readable display
4.	Power, distance reset, sonde, internal and external microphones and charging status indicator
5.	Lid assembly with keyboard
6.	Locking lid latch to keep the lid closed

Recording, Picture Capture, Playback, and Zoom Controls (top panel)

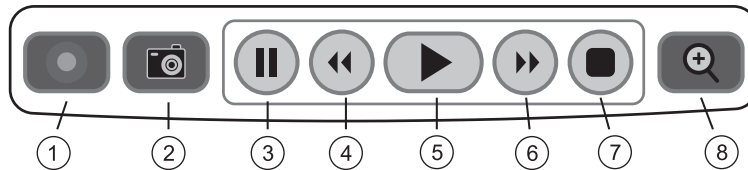

1	Start Recording	Use this key to start a recording. A red flashing recording icon will appear on the bottom left section of the status bar on the LCD screen and the elapsed recording time will appear bottom center.
2	Picture Capture	Use this key to take a jpeg format picture from live video, from the current recording session or from video playback. The picture icon will momentarily appear on the status bar confirming that a picture was taken.
3	Pause Recording	Use this key to pause the recording video. To resume recording press the pause button again and the pause icon will be replaced by the recording icon.
4	Rewind Video Playback	Use this key to rewind the currently playing video. Press up to 3 times again to increase the rewind speed.
5	Play Video	Use this key while viewing videos recorded on the control module. Press to resume a paused video.
6	Forward Video Playback	Use this key to forward through the currently playing video. Press up to 3 times again to increase the forward speed.
7	Stop Recording	Use this key to end a video recording session or to stop a video being played in the control module.
8	Digital Zoom	Use this key to zoom in on live video, recorded video or jpeg pictures. Press one time to bring up the red zoom box on the screen. Move the zoom box to the area to be magnified and press the enter key. While the zoom box is shown press up to three times more to increase the digital zoom level.

4 Initial Control Module Setup

Front Panel Controls

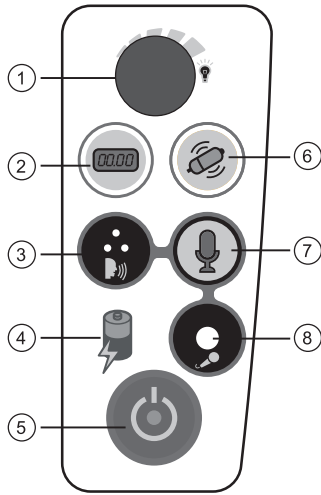

Features

1.	Camera LED Dimmer knob to raise, lower or turn off the camera's LED lighting.
2.	Distance Counter Reset key to reset the pushrod distance out to 0.
3.	Internal Microphone to record audio comments over the video recording.
4.	Battery Charging Indicator will glow red while charging and turn green when fully charged.
5.	Power On/Off control.
6.	Sonde On/Off control.
7.	Microphone On/Off control glows red when microphone is active.
8.	3.5mm Microphone Jack for use with an external microphone.

Media Ports (left side)

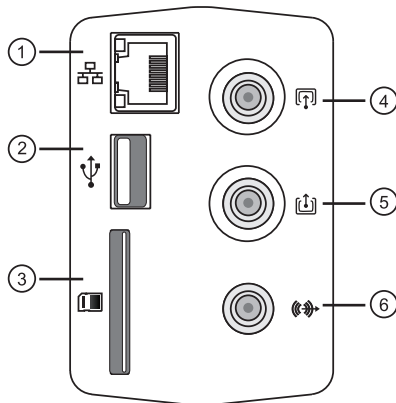

Feature

1.	RJ45 Ethernet Port to connect to laptops or PCs.
2.	USB Port for transferring video or pictures to a USB thumb drive.
3.	SD Card Slot for transferring video or pictures to a SD card.
4.	RCA Video Out Socket to connect to an external monitor or other devices.
5.	RCA Video In Socket to bring in audio from an external source.
6.	RCA Audio Out socket to connect to an external audio device.

Interconnect Ports (right side)

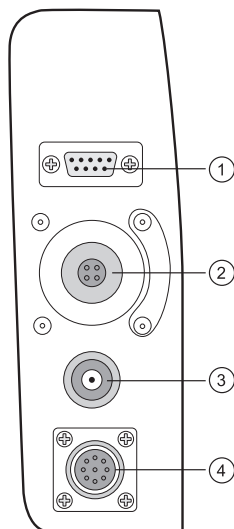

Feature

1.	RS232 Serial Port allows two-way communications with third party observation software.
2.	Camera Test Port to help troubleshoot the camera head.
3.	DC Power/Charging Socket provides DC power to run and charge the control module.
4.	Reel Interconnect Socket connects the reel to the control module by the interconnect cable.

4 Initial Control Module Setup

LCD Detail

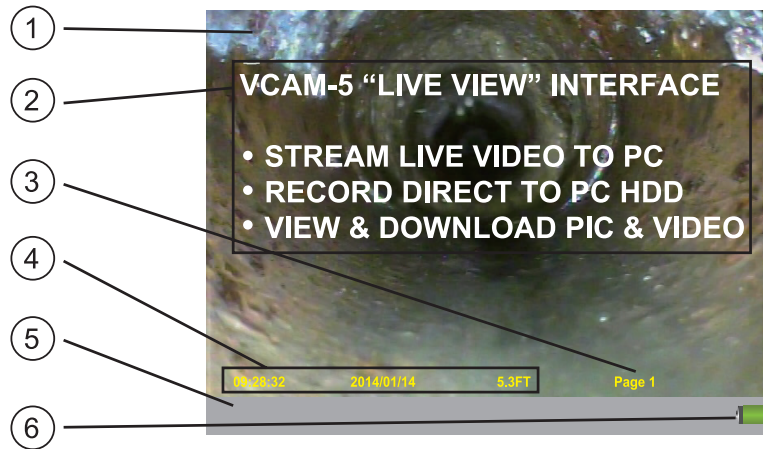

1.	LCD Screen
2.	Example of Text created by the Text Writer. (See section 6 for instructions)
3.	Text Writer Current Page Number, out of 20 pages.
4.	Time, Date and Distance out by the On Screen Display (OSD) F2 Info key.
5.	Status Bar shows the current control module's running features. The status bar can be hidden or displayed.
6.	Battery Status indicates if running on battery, AC/DC power or if the battery is currently charging.

Control Module Rear View



1.	The Model and Serial Number Label shows the model, manufacturing date code and serial number.
2.	Vent allows warm air from the microprocessor to escape and vent the housing.
3.	Fuse Compartment houses the fuse.
4.	Reel Mounting Locking Pin locks the control module atop the Type-CP Reel.
5.	The control module's Serial Number.
6.	Power Supply to monitor charging of the battery.
7.	Reel Mounting Pins to attach to the Type-CP Reel.

3.4. vCam Series Cable Reels Overview

The vCam series cable reels are used to store and control the deployment of the pushrod cable. The vCam series cable reels come in two sizes: a larger Type-CP, standard reel which is for day-to-day use, and a smaller more portable Type-M2 mini reel which is used for small diameter applications. Both the Type-CP and Type-M2 reels are supplied with an interconnect cable which connects the reel to the control module, as well as a pipe insertion sleeve to protect the pushrod against the opening of the pipe.

3.4.1. Standard Equipment - Reels

All vCam series cable reels include pushrod with an installed termination spring assembly. The vCam-5 control module can be mounted and locked on top of the larger Type-CP reel which allows for viewing at a comfortable height.

All vCam series reels with pushrod are supplied with:

1. **Interconnect Lead** - The interconnect cable connects the reel to the control module and sends the raw video signal and distance of pushrod deployed to the control module. From the control module this cable allows control of the sonde and camera head lighting.



2. **Insertion Sleeve** - The insertion sleeve is inserted into the mouth of pipe to prevent the pushrod from making direct contact with the pipe when deploying. This prevents chafing of the pushrod jacket and the end result will be prolonged life of the pushrod.



3.4.2. Type-CP Standard Reel

The Type-CP standard reel is available in 200ft/60m and 400ft/120m of standard (12mm diameter) pushrod cable. The Type-CP reels includes 8in/203mm solid rubber wheels for easy transport. The Type-CP reel can be used either in the vertical upright position or on its side in a horizontal position. The Type-CP reel has mounting brackets to lock the control module in place on top of the reel.

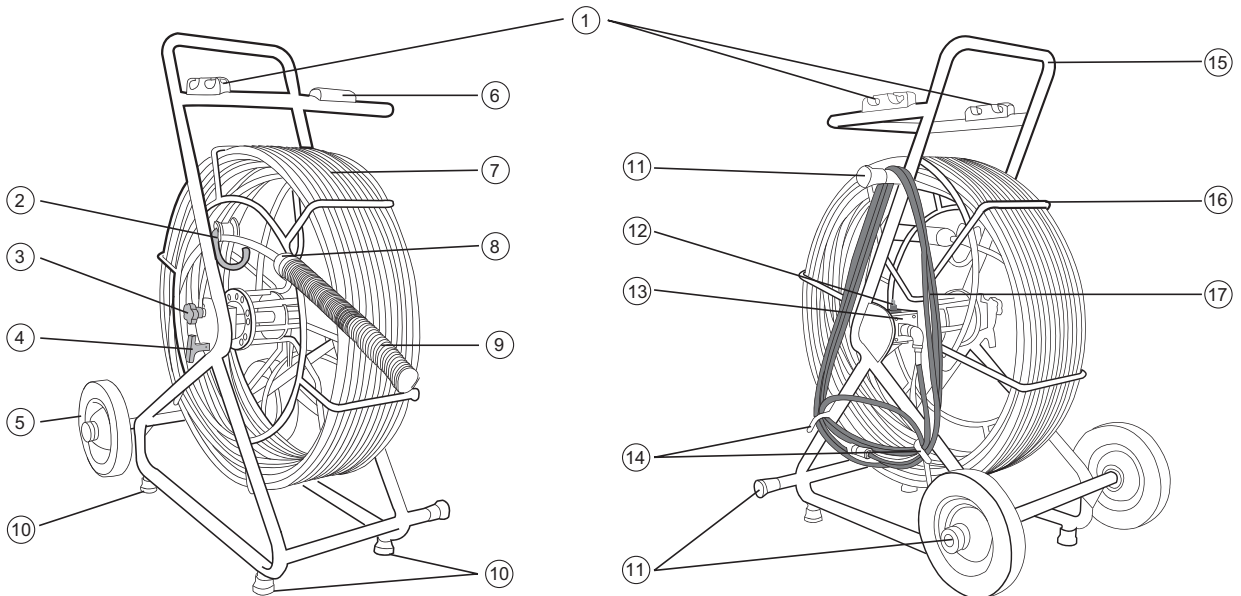

Type-CP Standard Reel

1.	Mounting Blocks	For mounting and locking the vCam-5 control module in place.
2.	Cable Guide Assembly	Helps control the deployment and retrieval of the pushrod cable by keeping it in a localized area.
3.	Friction Brake	To control the speed at which the cage spins.
4.	Locking Brake	To lock the cage in place for transport.
5.	Wheels	Tilt the reel back by the handle and use the wheels for easy transport.  WARNING Do not use the control module as a handle to move the reel. Use the handle on the reel only.
6.	Keyboard Lid Resting Block	When open, the control module lid rests on this block to keep it level.
7.	Pushrod Cable	The Type-CP reel is available in 200ft/60m and 400ft/120m of standard (12mm diameter) pushrod cable.
8.	Sonde Cup	The sonde locate signal emits from this cup. This locate signal can be picked up on the surface by a utility or sonde locator with matching frequency.
9.	Spring Termination Assembly	Attaches to the pushrod and gives flexibility to lead the pushrod through bends in the pipe.
10.	Rubber Feet, bottom	Helps to keep the reel in place on slippery surfaces and to protect finished floors.
11.	Horizontal Position Legs	Allows the reel to be used on its side in a horizontal position.
12.	Pushrod Trace Post	Connect the hot lead of a utility locator transmitter to the rod trace post and the ground lead to earth to send a locate signal through the entire length of pushrod.
13.	Counter Block Assembly	Houses the electronics used for distance counting and pushrod tracing. The serial number label is mounted to the side of the assembly.
14.	Cable Hooks	To store the interconnect cable in place when not in use.
15.	Reel Frame	Holds the cable cage in place and allows for easy transport of the reel.
16.	Pushrod Cable Cage	Houses the pushrod, and allows deployment and retrieval of the pushrod.
17.	Interconnect Cable	Provides control module to reel connection for video feed, sonde operation, distance counting and camera LED lights.

3.4.3. Type-M2 Mini Reel

The Type-M2 mini reel is a smaller portable hand-carried reel available in 100ft/30m or 200ft/60m of mini (10mm diameter) pushrod cable.

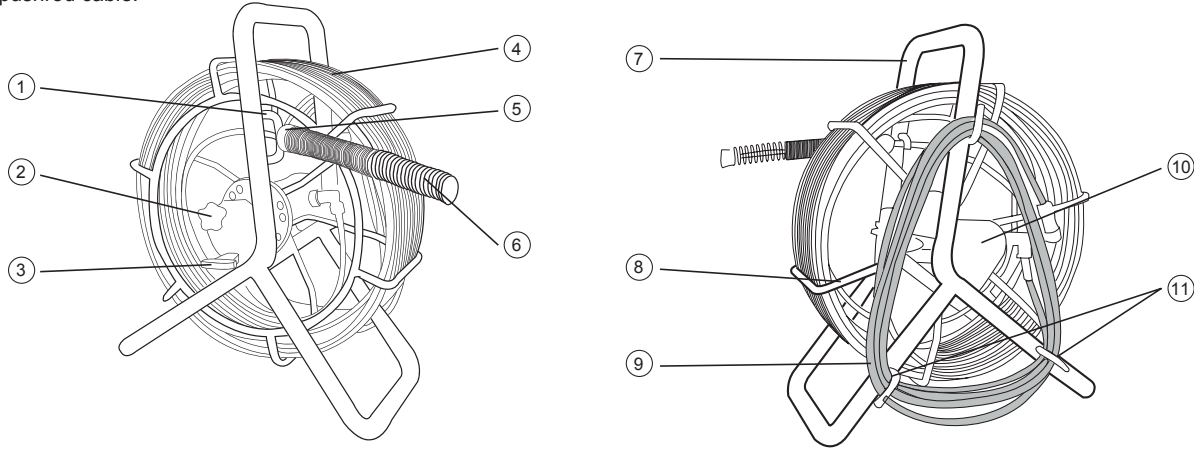

Type-M2 Mini Reel

1.	Cable Guide	Helps control the deployment and retrieval of the pushrod cable by keeping it in a localized area.
2.	Locking Brake	To lock the cage in place for transport.
3.	Friction Brake	To control the speed at which the cage spins.
4.	Pushrod Cable	The Type-M2 reel is available in 100ft/30m or 200ft/60m of mini (10mm diameter) pushrod cable.
5.	Sonde Cup	The sonde locate signal emits from this cup. This locate signal can be picked up on the surface by a utility or sonde locator with matching frequency.
6.	Spring Termination Assembly	Attaches to the pushrod and gives flexibility to lead the pushrod through bends in the pipe.
7.	Reel Frame	Holds the cable cage in place and allows for easy transport of the reel.
8.	Pushrod Cable Cage	Houses the pushrod, and allows deployment and retrieval of the pushrod.
9.	Interconnect Cable	Provides control module to reel connection for video feed, sonde operation, distance counting and camera LED lights.
10.	Counter Block Assembly	Houses the electronics used for distance counting and pushrod tracing. The serial number label is mounted to the side of the assembly.
11.	Cable Hooks	To store the interconnect cable in place when not in use.

3.4.4. Termination Spring Kits

The termination spring is available in different lengths and configurations, allowing for customization and use in a variety of applications and conditions. For example, a short length spring would be ideal in a larger diameter pipes due to having less side-to-side camera movement whereas a longer spring would better suit a pipe with multiple bends and elbows.

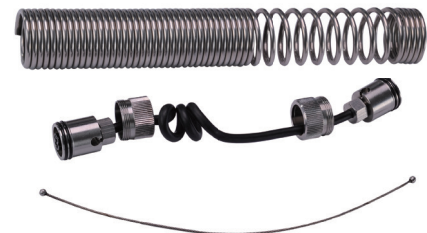

A complete list of available spring kits and other termination components are listed in the Components, Options and Accessories section of this manual section 9.2.4 Termination Part List.

3.5. Camera Head Overview

Camera Head Face

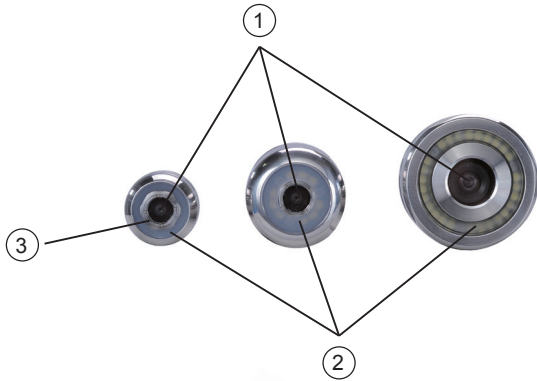

1.	Sapphire Glass Lens
2.	Polycarbonate LED Cover
3.	Focus Ring (D25 cameras only)

Camera Head Body



1.	Camera Base Threads
2.	Skid Screw Grooves
3.	Main Housing

Camera Head Back

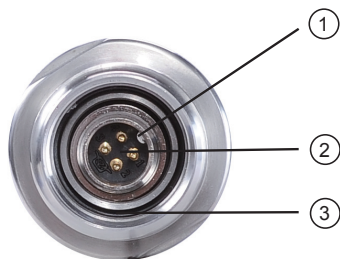

1.	Alignment Key
2.	Connector Contact Pins
3.	Base O-Ring

4. Initial Control Module Setup

4.1. Initial Control Module Setup

4.1.1. Installing the Fuse

Install the 10 Amp - 250 Volt fuse in the fuse compartment on the back of the control module. The control module will operate without a fuse when using AC power but the battery will not charge and the unit will turn off when the AC power is removed.

The fuse holder is located at the bottom left-hand area on the back of the control module. Two 10 Amp 250 Volt fuses are included in the control module accessory bag.

1. Use a screwdriver to unscrew and remove the fuse holder cap. Be sure to use the correct size screwdriver to prevent breaking the fuse holder slot.



2. Insert the 10 Amp 250 Volt fuse into the fuse holder cap.



3. Screw the fuse holder cap with fuse into the control module by hand as far as possible then use a screwdriver to tighten.



4.1.2. Charging the Internal Battery

Plug the supplied power cable in to a live electrical socket. The charging icon on the front panel of the control module will glow red while charging and glow green when fully charged. The typical charging time to fully charge a completely discharged battery will be approximately five hours and provide approximately five hours of use.



NOTE

Note that the first time the unit is charged that the battery icon may not read 100% charged. Let the control module's battery discharge to at least 25% and now when it is charged again the battery icon will read 100% charged.

4.1.3. The Interconnect Cable

To bring the video onto the screen plug the reel's interconnect cable into the control module. This is a keyed plug and socket so be sure to line up the red dot on the interconnect cable plug to the same red dot on the interconnect socket on the control module. Pull back the knurled ring on the connector and insert into the socket, release the knurled ring. Check that the connection is secure by giving a slight wiggle and tug. To remove the interconnect cable pull back the knurled ring and pull the plug out.



Keyed Connector

If a reel with a camera attached is not available or inconvenient, then plugging a camera head into the camera test port will have the same results.

4.1.4. About Control Module Settings

The initial setup of the vCam-5 control module is done with the keyboard. A USB or wireless mouse can also be used. All of the settings selected are saved into the control module's memory and will remain until changed. Note that the settings will be lost if the unit is reset to factory defaults, running certain firmware updates or by formatting the hard drive. The reel and camera do not need to be connected to the control module for the first time setup.

The initial control module will set the default storage for videos and pictures, metric or imperial distance measurement, date and time formats, sonde frequency, language and type of reel being used with the control module.

4.2. Navigating through the Setup Menu

It is recommended to set your language first so that all the other menus can be easily read and understood. See section 4.2.2 Setting the Control Module Language on setting the system language.

As long as the control module is attached to a reel with a camera or a camera head is inserted into the camera test port, a video image will be shown on the screen. While working in the Main or Setup Menu the video image will still be shown but it will appear darkened.

The vCam-5 control module has two main menus which are the **File** menu and **Setup** menu. Both of these main menus contain sub-menus.





This section will concentrate on the **Setup Menu**.

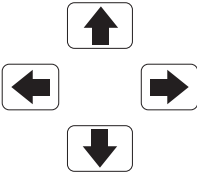

Pressing the keyboard **F10** key once will bring up the **File** menu, pressing twice will bring up the **Setup** Menu. Pressing the **ESC** key twice will close either menu and return to the main viewing screen.

4.2.1. Keyboard Keys used in the Setup Menu

	<p>Directional Arrows:</p> <p>Pressing the directional up ↑ and down ↓ arrow keys moves through the list of options in the Setup menu. As the up ↑ /down ↓ arrow keys are moved, the selection is highlighted in yellow. Stop on the desired option then press Enter or use the right → arrow key to see the choices within the selected menu option.</p>
	<p>Enter Key:</p> <p>Pressing the Enter key will confirm the selected item. Furthermore, pressing the Enter key while in a sub-menu will confirm the selection with a green check-marked box <input checked="" type="checkbox"/>.</p>



NOTE

The green check-marked box is used in the **Default Storage, Distance Counter, Sonde, Video Out and Reel Selection Options.**

	<p>ESC Key:</p> <p>Pressing the ESC key while in any menu or sub-menu will take the screen back to the previous menu. Press the ESC key repeatedly to return to the main viewing screen.</p>
---	---



NOTE

This user handbook will cover each item in the **Setup** menu starting with the **Language** sub-menu. After that the user handbook will cover each item in the **Setup** menu order from top to bottom.

i.e. **Language, then Default Storage, Format, Distance Counter and so on.**

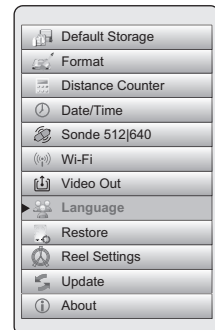

4.2.2. Setting the Control Module Language

1. Press the **F10 Menu** key twice to bring up the **Setup** menu.
2. Use the **down** ↓ arrow key to highlight the **Language** option.
3. Press **Enter** or use the **right** → arrow key to move into the sub-menu with the list of languages.
4. Use the **down** ↓ arrow key to highlight the desired language to use.
5. Press the **Enter** key to confirm the choice.

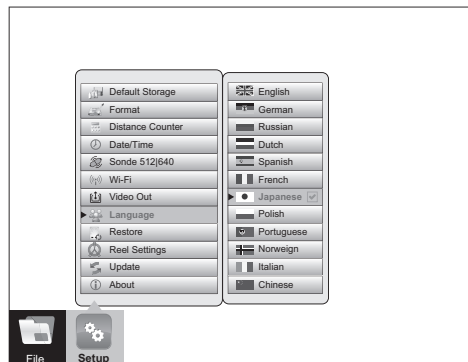

4 Initial Control Module Setup

6. A dialog box will appear stating the system will reboot to complete the change.
7. Press the **Enter** key to select **OK** to complete the process. The control module will re-boot and the language will be changed when it starts again.



WARNING
The control module must reboot in order to make this change.

4.2.3. Setting the Default Storage

Setting the Default Storage selects which drive (SD, Hard Drive or USB) will be used as the default. If the hard drive is selected all video recordings and pictures will be saved to this drive. If SD or USB is selected as the default this setting will be lost when the SD card or USB drive is removed from the control module.

1. Press the **F10 Menu** key twice to bring up the **Setup** menu.
2. Select the **Default Storage** option at the top of the selection list.
3. Press **Enter** or use the **right** → arrow key to move to the sub-menu with the list of options.

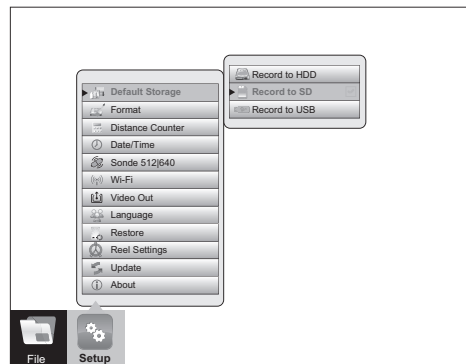

NOTE
SD and USB drives will only be shown if their devices are plugged into the control module at this time.



NOTE
If the SD or USB drives are set as default, when the SD or USB is removed, the Hard Drive will be reset as the default drive.

4. Use the **down** ↓ and **up** ↑ arrow keys to select the default storage choice.
5. Press the **Enter** key when the choice is highlighted and the white box will be filled with a green check confirming the selection.
6. Press the **ESC** key to return to the main **Setup** menu, press **ESC** key twice to return to the main viewing screen.
7. From the main viewing screen press the **F10** key once to bring up the **File** menu. At the **top of the** main **File** menu, the selected default drive is shown along with the amount of free space available and the total size of the drive.

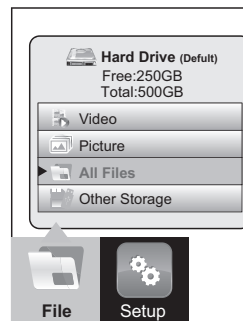

4.2.4. Setting the Distance Counter

The distance counter sets the unit of measurement to be used. The choices are imperial (feet) or metric (meters). The distance of pushrod deployed will be shown on the main screen above the status bar and will appear in videos and pictures when this feature is activated by using the **F2 Info** key.



NOTE

The distance counter is for reference only. It is important that you verify the actual position and depth with a Sonde Locator or Pipe & Cable Locator before excavating.

1. Press the **F10 Menu** twice to bring up the **Setup** menu.
2. Use the **down ↓** arrow key to scroll down to the **Distance Counter** selection.
3. Press **Enter** or use the **right →** arrow key to bring up choices of **Feet** or **Meters**.
4. Use the **up ↑** / **down ↓** arrow keys to highlight the choice.
5. Press the **Enter** key when the choice is highlighted and the white box will be filled with a green check confirming the selection.

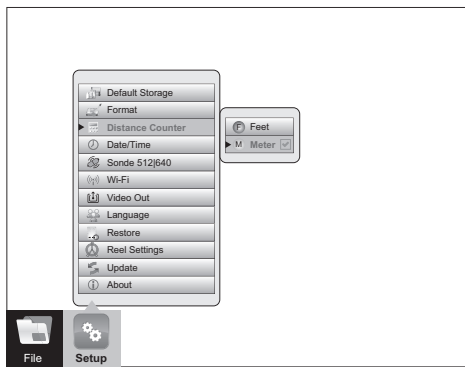

6. Press the **ESC** key to return to the main **Setup** menu, press **ESC** twice to return to the main screen.

4.2.5. Setting the Date, Time and Format

Setting the date/time allows the choice of three date formats, 12 or 24-hour time format and sets the date and time of the control module. The date and time will appear along with the distance of pushrod deployed will be shown on the main screen above the status bar and will appear in videos and pictures when this feature is activated by using the **F2 Info** key.

Date formats available are: **MM/DD/YYYY**, **DD/MM/YYYY** and **YYYY/MM/DD**



NOTE

In this section use:

1. **Right →** arrow key to move to selections of Date Format, Time Format and the area to set the date values.
2. **Up ↑** and **down ↓** arrow keys to make choices in the Date and Time Format sections.
3. **Left ←** and **right →** arrow keys to move between Month, Day, Year, Hour, Minute and Second values.

1. Press the **F10 Menu** twice to bring up the **Setup** menu.
2. Use the **down ↓** arrow key to scroll down to the **Date/Time** option.
3. Use the **down ↓** and **up ↑** arrow keys to move between the three date formats. When the selection is made and the red dot appears in the radio box it is time to move to the time options.

4 Initial Control Module Setup

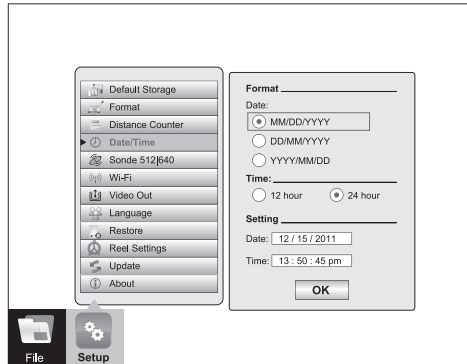

4. Use the **right** → arrow key to move into the time format selections.
5. In the time selection area, use the **up** ↑ and **down** ↓ arrow keys to move the red selector dot to either **12-hour** or **24-hour format**.
6. When the 12/24 hour choice is selected, use the **right** → arrow key to move into the date setup area.
7. Use the **up** ↑ and **down** ↓ arrow keys to increase the date value and use the **left** ← and **right** → arrow keys to navigate through month, day and year.
8. Move to the time values with the **right** → arrow key.
9. Use the **up** ↑ and **down** ↓ arrow keys to increase the time values and use the **left** ← and **right** → arrow keys to move to and from hour, minute and seconds.
10. Use the **right** → arrow key to select the **OK** key to save the changes.



NOTE

Pressing the Enter key at any time will save the changes made. This allows separate changes to be made at any time to either the time, time format or date without having to move through the entire selections available.

4.2.6. Setting the Sonde Frequency

Setting the Sonde frequency allows selection of either 512 Hz or 640 Hz frequencies when the Sonde On/Off button is pressed. Typically 640 Hz is used in Europe and the UK while 512 Hz is used in North America.

1. Press the **F10 Menu** key twice to bring up the **Setup** menu.
2. Use the **down** ↓ arrow key to scroll to the **Sonde Frequency** selection.
3. Press Enter or use the **right** → arrow key to bring up the sonde frequency choices.

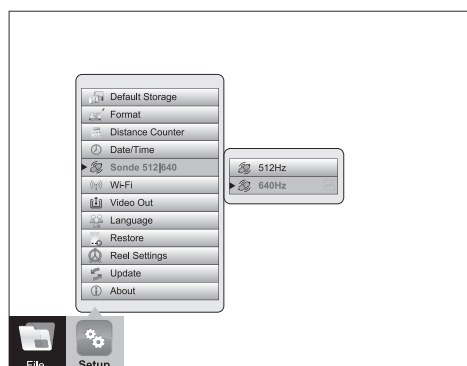

4. Use the **up** ↑ and **down** ↓ arrow keys to make your selection and press the **Enter** key to save them.
5. Press the **ESC** key to return to the main **Setup** menu, press **ESC** twice to return to the main screen.

4 Initial Control Module Setup



NOTE

If the sonde frequency was changed in the setup menu while the sonde was active, the change will not take effect until you turn the sonde off and then on again.

4.2.7. WiFi Administration

The WiFi administration sets the SSID, IP address and password for the control module's Wifi. This area is locked for factory and authorized repair use only.

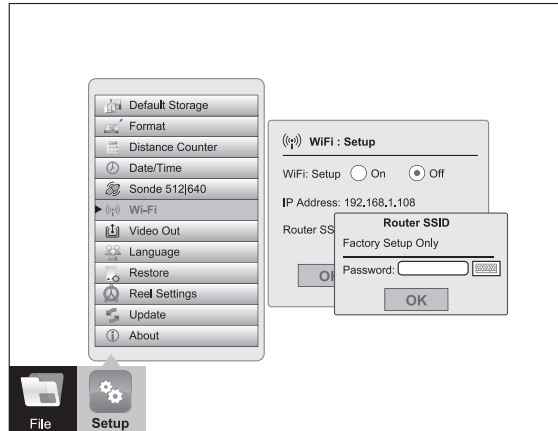

NOTE

This can be changed from this screen by an authorized service center or the factory. Please call to schedule an appointment to walk through the procedure. Using a wireless or wired USB mouse is recommended for this setting change.

4.2.8. Setting the Reel Type

This control module can be used with several types of Vivax-Metrotech pushrod reels. Selecting the correct reel type helps the control module calculate the distance of the pushrod deployed into a pipe. Know beforehand which model of reel and length of pushrod will be used.

1. Press the **F10 Menu** twice to bring up the **Setup** menu.
2. Use the **down ↓** arrow key to scroll to the **Reel Settings** selection.
3. Press **Enter** or use the **right →** arrow key to enter the reel choices sub-menu.
4. Use the **up ↑** and **down ↓** arrow keys to highlight the reel model type. Note that the Type-M and Type-CP reels offer a choice of pushrod length by pressing **Enter** again or using the **right →** arrow key.

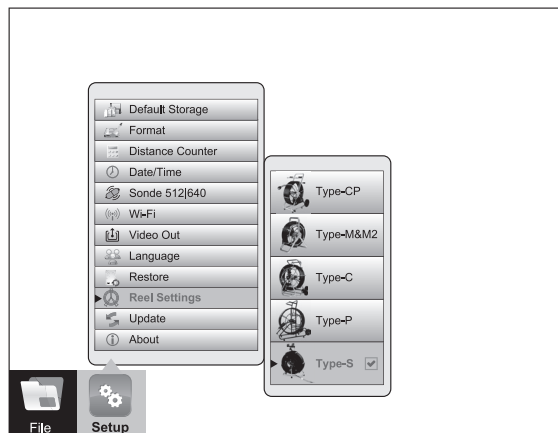

4 Initial Control Module Setup

5. Highlight the reel choice and sub-menu length choice if applicable.
6. Press the **Enter** key to save the changes.
7. Press the **ESC** key to return to the main **Setup** menu, press **ESC** twice to return to the main screen.



NOTE

The distance counter is for reference only. It is important that you verify the actual position and depth with a Sonde Locator or Pipe & Cable Locator before excavating.

4.2.9. Restore the Factory Default Settings

Restoring the default settings will erase all the settings on the control module and return it to the factory default. This will not erase any videos or images on the hard drive.

1. Press the **F10 Menu** twice to bring up the **Setup** menu.
2. Use the **down ↓** arrow key to scroll down to the **Restore** selection and press **Enter**.

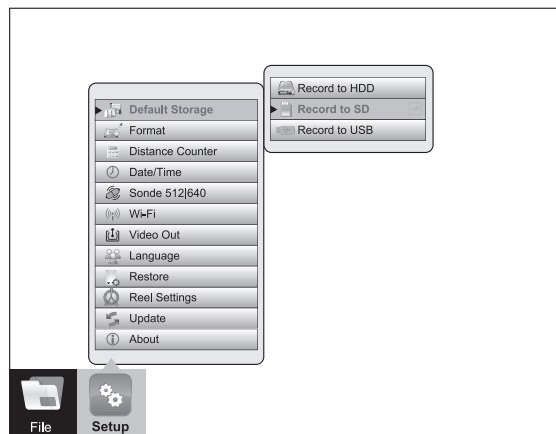

3. Use the **left ←** and **right →** arrow keys to select **OK** or **Cancel**.
4. Pressing **OK** will restore all settings to the default factory settings. **Cancel** will cancel the operation, and no changes will be made.

4.2.10. Update the Control Module Firmware

This option allows upgrading of the control module's firmware (software). Firmware upgrades come in the form of ".bin" (for DVR updates) and ".soc" (for processor updates) extension files. It may be necessary to upgrade one or both of them and the order in which they are updated does not matter. The firmware files can be obtained from an authorized service center or the local Vivax-Metrotech office. USB thumb drive or SD cards can be used to do the update.

The firmware update files must be installed on the **SD or USB devices "root directory"**. Specifically the files must be visible when viewing the contents of the SD or USB device. The files **cannot be compressed or in a folder**.

WARNING

DO NOT INTERRUPT THE UPDATE ONCE IT HAS STARTED.

Update the firmware with the control module while running under AC power.



Some updates will delete any videos or images on the control module's hard drive. It is highly recommended that you move these videos and images on the hard drive off the control module and into a PC or Laptop.

Check the "read me" text file that comes with the firmware update files for any specific hardware, version or lot information on the control module. Certain Microcontroller Unit (MCU) updates are limited to early hardware versions.

4 Initial Control Module Setup

Wait, the control module will reboot after the firmware installation is complete. Leave the control module alone until it reboots. Some time may lapse between the progress indicator disappearing and the re-boot.



TIP

Make a note of the control module's current software version before running the update. When the update is completed you can compare the before and after versions.

1. Extract the firmware update files and copy the .bin and or .soc file to a SD or USB device. **The files must be on the root drive of the drive or card, i.e. the files must not be compressed or in a folder on the device.**
2. Plug the SD or USB device into the control module.
3. Press the **F10 Menu** key twice to bring up the **Setup** menu.
4. Use the **down** ↓ arrow key to scroll down to the **Update** sub-menu. Press **Enter**.

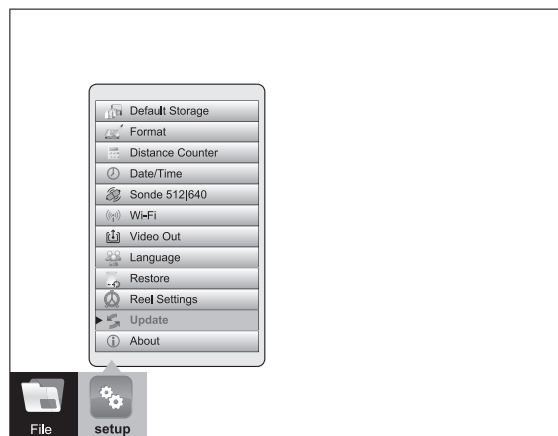

5. Use the **up** ↑ and **down** ↓ arrow keys to highlight and select **Update Firmware** and press the **Enter** key.

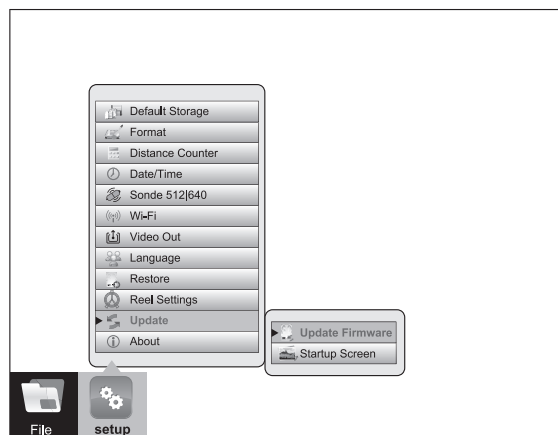

6. Use the **up** ↑ and **down** ↓ arrow keys to select either the SD or USB device which has the firmware loaded onto it. Press the **Enter** key.

4 Initial Control Module Setup

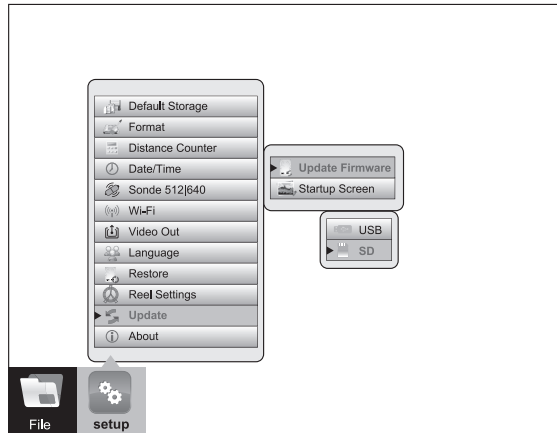

7. Use the **up** ↑ and **down** ↓ arrow keys to select which type of file is being used for the update, .bin or .soc and press **Enter**.

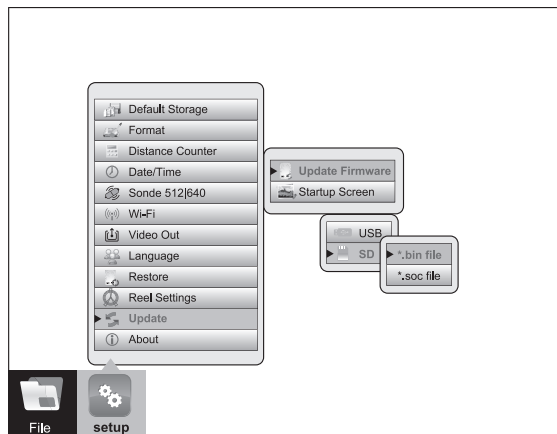

8. Use the **up** ↑ and **down** ↓ arrow keys to highlight and select the .bin or .soc file and press **Enter**.

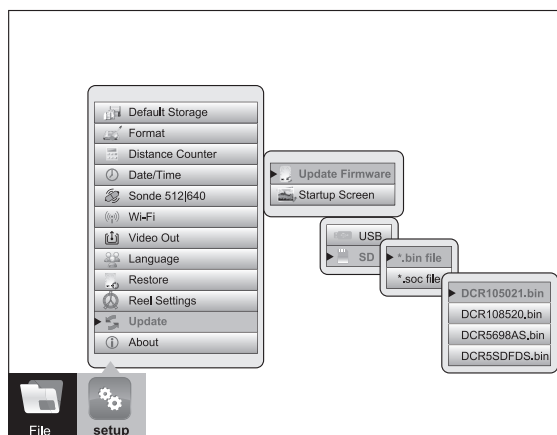

9. A dialog box should appear confirming the firmware update. Use the **left** ← and **right** → arrow keys to select **OK** or **Cancel** and press the **Enter** key.

4 Initial Control Module Setup

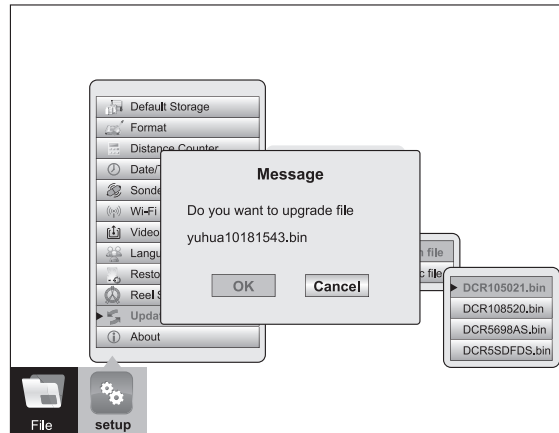

10. The update is now in progress and a progress indicator will appear. Leave the control module running and **do not interrupt** the update. The control module will re-boot when it is finished. **The control module must re-boot to complete the update.**

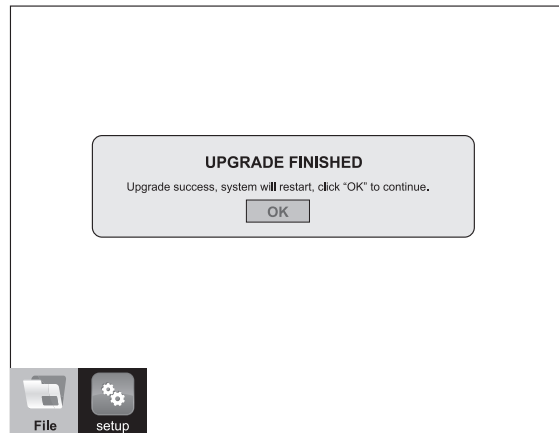

11. Repeat these steps if both the .bin and .soc file need to be updated.
12. Verify that the firmware update was successful by checking the firmware version in the **About** section of the setup menu.

4.2.11. Update the Control Module Start Screen

This option allows the personalization of the second start screen seen when the control module is starting. A company name, logo and phone number is an example of how to customize this screen. Any image, text or logo can be used as long as it is in a JPEG image format.

To use a picture it must be:

- JPEG format
- 24 or 32 bit color depth
- 700 x 480 pixels
- 96 dpi

If larger or smaller images are used, the picture seen on the screen may be distorted.

1. Load the jpeg format image file onto a SD or USB device.
2. Insert the device containing the jpeg image into the control module's SD or USB port.
3. Follow steps 1 through 5 in section 4.2.10. Update the Control Module Firmware, on how to update the firmware. Use the **right** → arrow key to highlight and select the **Startup Screen** selection and press the **Enter** key.

4 Initial Control Module Setup

4. Use the **up** ↑ and **down** ↓ arrow keys to select the USB or SD device from the sub-menu which has the image file loaded onto it. Press the **Enter** key.

4.2.12. The About Screen

The about screen shows the control module's current "firmware" (software) version, the firmware release date, and the current video format (NTSC or PAL) being used. The two types of firmware are (1) the DVR and (2) the MCU.

You will be asked for the firmware version if calling for technical support.

1. Press the **F10 Menu** twice to bring up the **Setup** menu.
2. Use the **down** ↓ arrow key to scroll down to the **About** selection.
3. Press **Enter** and the firmware version information will be displayed.

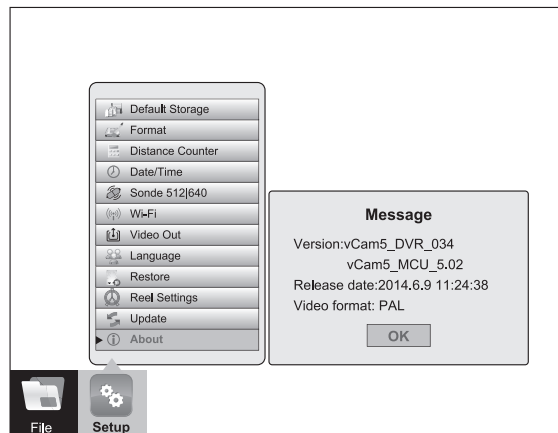

4. Use the **left** ← arrow key or **ESC** key to return to the **Setup** menu.

4.2.13. Video Out

When using the video out socket with certain LACP Observation Software, changing the video out setup may be needed. Check with the software manufacturer if this setup option is required.

1. Press the **F10 Menu** twice to bring up the **Setup** menu.
2. Use the **down** ↓ arrow key to scroll down to the **Video Out** selection.
3. Press **Enter** and the choices of **Camera** and **CVBS** are shown.

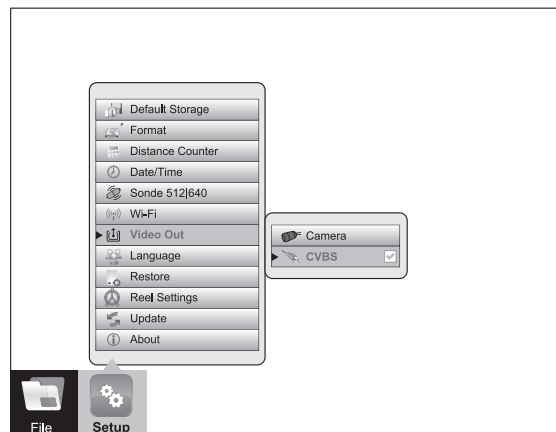

4. Use the **up** ↑ and **down** ↓ arrow keys to make the selection. Press the **Enter** key.
5. Use the **left** ← arrow key or **ESC** key to return to the **Setup** menu.

5. Video Recording and Picture Image Capture

5.1. Overview

This section of the manual covers video recording, capturing images, reviewing videos and pictures, and copying, moving and deleting video and picture files. To accomplish these items we must understand the menu system, file system and navigation in them.

5.2. Main File Menu

The vCam-5 control module uses a cascading menu system which primarily uses the **left** ←, **right** →, **up** ↑, **down** ↓ arrow keys, **Enter**, and **ESC** keys to move through the menus and sub-menus. A yellow bar will always highlight the current position and selection. A wireless mouse can also be used to move around the menus. Although this may not be a practical feature to use in the field it may be helpful when working in the office.

The menu system consist of:

- a. Main File menu
- b. File List sub-menu
- c. File Option sub-menu
- d. Media Select sub-menu

Use the **F10 Menu**  key to bring up the main File menu.

The main **File** menu contains four parts. From top to bottom they are:

	<ol style="list-style-type: none"> 1. Video – The video section of the main menu will show only video files on the hard drive or other storage. Use the right → arrow key to advance to the next sub-menu (file list sub-menu) to see the list of video recordings stored on the control module's hard drive, USB drive or SD card. 2. Picture – The picture section of the main menu will show only picture files on the hard drive or other storage. Use the right → arrow key to advance to the next sub-menu (file list sub-menu) to see the list of pictures stored on the control module's hard drive, SD or USB device. 3. All Files - The all files section of the main menu will show both picture files and video files on the hard drive or other storage. Use the right → arrow key to advance to the next sub menu (file list sub-menu) to see the list of pictures and videos stored on the control module's hard drive, SD or USB device. 4. Other Storage - Allows viewing of both videos and pictures on a SD or USB device that is currently plugged into the control module. In the other storage view, the total size and amount of free space of the SD or USB device can be seen.
---	--

To view the contents of a USB thumb drive or SD card:

1. Insert a USB thumb drive or SD card into the control module.
2. Use the **down** ↓ arrow key to select and highlight **Other Storage**.
3. Use the **right** → arrow key to advance to the next sub-menu (file list sub-menu) to see the list of JPEG images stored on the control module's SD or USB device that is currently plugged into the control module.



NOTE

Only videos or pictures that were originally created in the control module will appear in the file list sub-menu and be viewed on the control module.

5.2.1. File List Sub-Menu

The file list sub-menu shows the list of files, videos and or pictures, which are on the hard drive. Contents of a SD or USB device can also be viewed if they are currently plugged into the control module. In the video file list sub-menu pausing on a video file will start a preview window, the file preview dialog box will also show the length of the video and its size in MB.

File Select Sub-Menu

	<p>1. Next page scroll direction – Scroll to the next page of files by using the Page Down key.</p>
	<p>2. Page number – Indicator of which page number and total number of pages.</p>
	<p>3. File name – File name consist of YY MM DD HH MM. When multiple pictures are taken within one minute of time an alpha character will be added to the end of the file name.</p>
	<p>4. Selection check box – Pressing the Enter key while on a highlighted file will add a green check mark. Use this to select multiple files.</p>
	<p>5. Previous scroll direction – Scroll to the previous page of files by using the Page Up key.</p>
	<p>6. Picture/video icon – While viewing all files this icon describes a video of picture file.</p>

From the main **File** menu use the **right** → arrow key to move to the file list sub-menu.

The **up** ↑ and **down** ↓ arrow keys moves through the list of video or picture files in the file list sub-menu. The current file selected is always highlighted in yellow and will have a green outlined check mark to the right. Pressing the **Enter** key while on a highlighted file will add a green check mark to the right of the file name. Multiple files can be selected by moving from file to file with the **up** ↑ or **down** ↓ arrow keys and pressing **Enter** on each file to be selected.

Moving from page to page - The file list sub-menu may contain multiple pages with six files per page. The top right section of the sub menu shows the current page and the total number of pages. For example if “2/14 “ is showing this means page two is the current page out of a total of 14 pages.

To move from page to page use the **up** ↑ / **down** ↓ arrow keys to highlight the bottom row **Next** or the top row **Previous**. After the **Next** or **Previous** row is highlighted use the **left** ← or **right** → arrow keys to move either forward or backward a page at a time.

Selecting multiple files:

Each file in the file list sub-menu has a green outlined box to the right of the file. Highlight a file in the list and press the **Enter** key, now the box to the right will show a green check symbol in it. Repeat these steps for each file you wish to select. Multiple files can be copied across several pages.



TIP

Use the **TAB** key while in the **File Select** sub-menu to select the entire page of videos or pictures.



TIP

In the video file list sub-menu momentarily pausing on a file in the list will start a preview window, the file preview dialog box will also show the length of the video and its size in MB. Using the **Text Writer** during the start of the video recording will allow you to easily identify your target video. The text shown on the recorded video will also be seen during the video preview.**NOTE**



NOTE

The video preview should take four to five seconds to appear and start playing. The fewer videos you have on the hard drive the faster the preview will begin. When the hard drive fills with videos and pictures the preview will take longer to pop up and play.

5.2.2. File Option Sub-Menu

The **File Option** sub menu shows the options available for files selected in the previous file list sub menu.

The File Options sub-menu consist of:

	<p>1. Play Video or View Picture – The Play option will start playing the recorded video or view an image file. Pressing the ESC key twice will stop the playing video or close the image view and return to the previous sub-menu.</p>
	<p>2. Copy Video or Picture - The Copy option will make a copy of the selected video(s) or picture(s) and copy it to a USB drive or SD card. The Copy option makes a copy of the video or picture and leaves the original on the default storage drive.</p>
	<p>3. Move Video or Picture – The Move option will remove the selected original video(s) or picture(s) from the default drive and move it to the USB drive or SD card. No copy of the file will remain on the default drive.</p>
	<p>4. Delete Video or Picture – the Delete option will delete the selected video(s) or pictures(s) from the default drive. No copy is retained and a file cannot be recovered after it is deleted.</p>
	<p>5. Rename Video or Picture – The Rename option allows the re-naming of files on the control modules hard drive. When selected up-to 11 alpha-numeric characters can be used to rename the file.</p>



NOTE

Files moved off of the control module hard drive cannot be placed back on the control module. Files deleted from the control module cannot be recovered.

5.2.3. Media Select Sub-Menu

The **Media Select** sub-menu will show the media available (SD or USB device) available (plugged in) and select the destination of the file being copied or moved.

Media Select sub-menu options









	<p>1. USB – Selecting USB will move the selected video(s) or picture(s) to the USB thumb drive that is plugged into the control module.</p>
	<p>2. SD - Selecting SD will move the selected video(s) or picture(s) to the SD card that is plugged into the control module.</p>



NOTE

After plugging a USB thumb drive or SD card it will take approximately 20 seconds for the control module to recognize it. The USB thumb drive or SD card should be plugged in while at the main viewing screen and not when in the Main File menu or any other sub-menus.

The control module will recognize USB thumb drives up to 128GB in size and SD cards up to 64GB in size.

	<p>F10 Menu key</p>	<p>Press once to bring up the main file menu, press again to bring up the setup menu. The main file menu is the day-to-day menu used most often while the setup menu is used to make changes to the control module functions or options.</p>
	<p>Left and Right arrow keys</p>	<p>The Left and Right arrow keys move through the file sub-menus.</p>
	<p>Up and Down arrow keys</p>	<p>The Up and Down arrow keys scroll the list of video and picture files in the file list sub-menu, scrolls the choices in the file option sub-menu and scrolls the options in the media select sub-menu.</p>
	<p>Enter File List sub-menu File Option sub-menu Media Select sub-menu</p>	<p>Pressing the enter key while in the;</p> <p>Select the file by adding the green check box to the far right.</p> <p>Start the action of play, copy, move or delete.</p> <p>Start the file movement to the SD or USB drive.</p>
	<p>Page Up and Page Down</p>	<p>The Page Up and Page Down keys will scroll one complete page at a time through the file list sub-menu.</p>
	<p>Tab</p>	<p>Use the Tab key while in the file select sub-menu to select the entire page of videos or pictures.</p>
	<p>ESC</p>	<p>Use the ESC key while in any menu or sub-menu to step back one step. Press the ESC key repeatedly to return to the main viewing screen. Pressing the ESC key while in a file copy or movement will stop that operation.</p>
	<p>F1 Help</p>	<p>The F1 Help key will display give a brief overview of the options and commands of the control module.</p>

5.3. Video Recording and Playback Controls

Video recordings will be saved to the default drive selected in the initial control module setup.

By default all videos and pictures will be saved to the internal hard drive. If recording direct to a SD or USB device, insert the device and make sure the default drive is set to either the SD or USB device.



TIP

Leave the hard drive as the default drive. The contents of the hard drive can be copied to USB drives or SD cards while still retaining the original videos and pictures.



TIP

Keep as much free space on the hard drive as possible. The menu system will work more efficiently with fewer files on it. Keeping the hard drive free also limits loss in the case of a catastrophic event.

Recording, Picture Capture, Playback, and Zoom Controls (top panel)

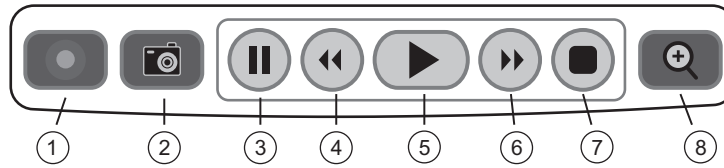

1.	Start Recording	Use this key to start a recording. A red flashing recording icon will appear on the bottom left section of the status bar on the screen and the elapsed recording time will appear bottom center.
2.	Picture Capture	Use this key to take a jpeg format picture from live video, from the current recording session or from video playback. The picture icon will momentarily appear on the status bar confirming that a picture was taken.
3.	Pause Recording	<p>Press the Pause key to pause the recording video. While the video is paused the pause icon will appear on the bottom left section of the status bar on the screen and the elapsed recording time will pause.</p> <p>To resume recording, press the Pause key again and the pause icon will be replaced by the recording icon.</p> <div style="display: flex; align-items: center;">  <p>NOTE When recording is paused the system clock keeps running. When playing back the video you will see a jump forward in the time shown on the video. (If the clock was showing while the video was recording).</p> </div>
4.	Rewind Video Playback	Use this key to rewind the currently playing video. Press up to three times again to increase the rewind speed.
5.	Play Video	Use this key to play a video from the File Select list or to resume playing a paused video.
6.	Forward Video Playback	Use this key to forward through the currently playing video. Press up to three times again to increase the forward speed.
7.	Stop Recording	Use this key to end a video recording session. The recording will stop and be saved to the default drive. Also use this key to stop a video being played in the control module.
8.	Digital Zoom	Use this key to zoom in on live video, recorded video or jpeg captures. Press once to bring up the red zoom box on the screen. Move the zoom box to the area to be magnified in on and press the Enter key. While the zoom box is shown press up to three times more to increase the digital zoom level.

5.3.1. Making a Video Recording

Videos will be saved to the default drive you selected in the initial control module setup. If no other drive is selected the videos will be saved on the internal hard drive.

1. Press the **Record**  icon on the top panel keypad.
2. The recording icon will appear on the status bar on the screen. When the record icon starts flashing is when the recording begins. In the center of the status bar the elapsed recording time will be displayed in hours, minutes and seconds.
3. The video will continue to record until the video is stopped by pressing the **Record** key again or using the **Stop** key.

During a video recording the following options are operational and usable:

- WiFi
- Sonde
- Microphones
- Full Text writer
- Camera LED control

5 Video Recording and Picture Image Capture

- Distance counter reset
- F9 Display adjustments
- Take a JPEG image picture
- Pause the video for up to 30 minutes
- Use the digital zoom to view close up (view only, the zoom effect will not be recorded)
- Pushrod tracing (some interference may occur on the LCD)

5.3.2. JPEG Image Picture Capture

Pictures will be saved to the default drive you selected in the initial control module setup screen. If no other drive is selected the pictures will be saved on the internal hard drive.

1. Press the **Picture Capture**  key on the top panel keypad.
2. The picture icon and picture file name will appear momentarily on the bottom left of status bar confirming that the picture was taken and saved.
3. Pictures can be taken from live video, while a recording is in progress, or from a video being played back in the control module.



TIP

Use the **Text Writer** feature to add identifying text to the recording video and image captures. Now while looking at the preview in the file list sub-menu the text recorded on the video and pictures will help identify the target video or picture.

5.4. Play Videos and View Pictures in the Control Module

To Play Video Files:

1. Press the **F10 Menu** key to bring up the main **File** menu.
2. Use the **right** \rightarrow arrow key to move to the file list sub-menu.
3. Use the **up** \uparrow and **down** \downarrow arrow keys to scroll and highlight the video or picture to be viewed. When the file is highlighted, after a few seconds a preview of the video, its length and size will pop up.
4. Press the **Enter** key to select and check the file.
5. Use the **right** \rightarrow arrow key to move to the **File Option** sub-menu.
6. Use the **right** \rightarrow arrow key to select **Play** from the **File Option** sub-menu.
7. In the Media Select sub-menu highlight the play option and press **Enter**.

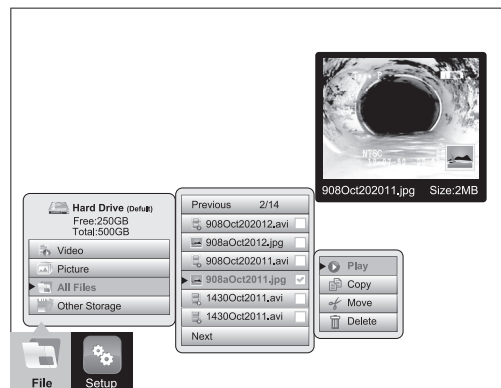

8. To stop the video playback; press the **ESC** key twice to return to the file list sub-menu or press the **Stop**  key on the top keypad.
9. During video playback the following options are operational and usable:
 - WiFi
 - Rewind and fast forward
 - Take a JPEG image picture
 - Pause the video for up to 30 minutes
 - Use the digital zoom to view close up (view only)

5 Video Recording and Picture Image Capture

5.4.1. View Picture Image Files:

1. Use the steps shown in section 5.4 Play Videos and View Pictures in the Control Module.
Only this time using picture images rather than video files.

5.4.2. Renaming a Video or JPEG Image File

Video and picture files on the control module can be re-named from the default date format used. File name can be up to 11 alpha numeric characters. !@#%\$%^&*() and . are characters that cannot be used to rename a file. After the file is renamed the location of the file is still at the same location in the file list as originally placed by the default date format file name.

1. Press the **F10 Menu** key to bring up the main **File** menu.
2. Use the **right →** arrow key to move to the file list sub-menu.
3. Use the **up ↑** and **down ↓** arrow keys to scroll and highlight the video or picture to be viewed. When the file is highlighted, after a few seconds a preview of the video, its length and size will pop up.
4. Press the **Enter** key to select and check the file.
5. Use the **right →** arrow key to move to the File Option sub-menu.
6. Use the **down ↓** arrow key to scroll and highlight the **Rename** option and press **Enter**.

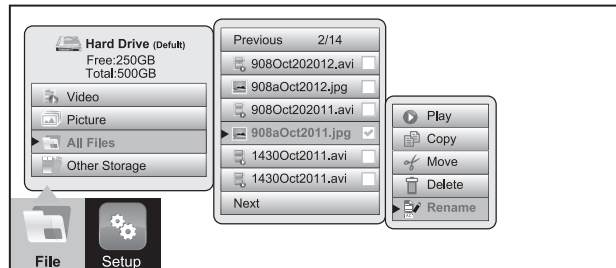

7. The file rename dialog box now appears. Enter up to 11 characters to rename the file and press the **right →** arrow key to bring up the **OK** confirmation box and press **Enter**.

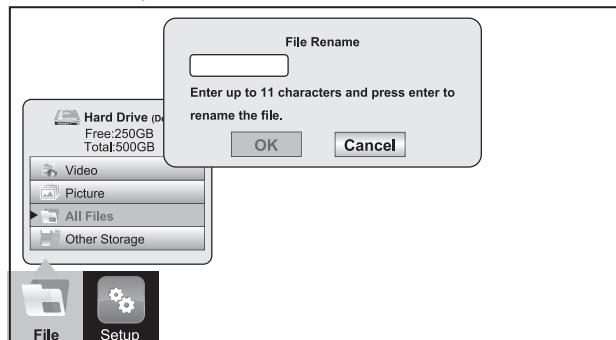

8. The file rename confirmation message will appear and disappear after four seconds.

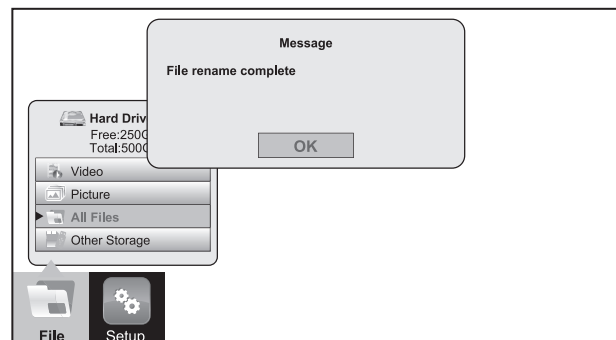

9. The file rename is now complete.

5 Video Recording and Picture Image Capture

5.4.3. Copy, Move or Delete Videos and Pictures

In the File Option sub-menu files can be copied or moved to an SD or USB device, or they can be deleted from the hard drive.

1. Plug an SD or USB device into the appropriate slot in the control module to copy or move files. Be sure that there is enough space on the SD or USB device being used.
2. Press the **F10 Menu** key to bring up the main **File** menu. Use the **up ↑** or **down ↓** arrow keys to scroll to and highlight **Video**, **Pictures** or **All Files**.
3. Press **Enter** or use the **right →** arrow key to move to the file list sub-menu.
4. Use the **up ↑** or **down ↓** arrow keys to highlight and select by pressing the **Enter** key, the files to move, copy or delete. Pressing the **Enter** key will place a green check mark to the right of the file name.
5. Use the **right arrow →** key to move to the file option sub-menu.
6. In the file option sub-menu use the **up ↑** or **down ↓** arrow keys to select **Copy**, **Move** or **Delete**.
7. If copying or moving files select copy or move and use the **right →** arrow key to move to the Media Select sub-menu. Select the destination for the file (SD or USB device) and press the **Enter** key to complete the action.

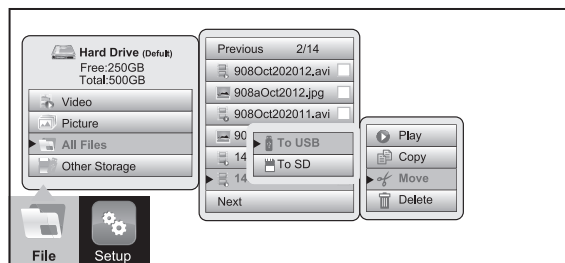

8. During the copy or move process a progress indicator bar will appear top center of the screen. This will show:
 - The specific file out of the total number of files being processed.
 - Total number of files to be processed.
 - Size in MB already processed.
 - Total size of all selected files.
 - Cancel option.

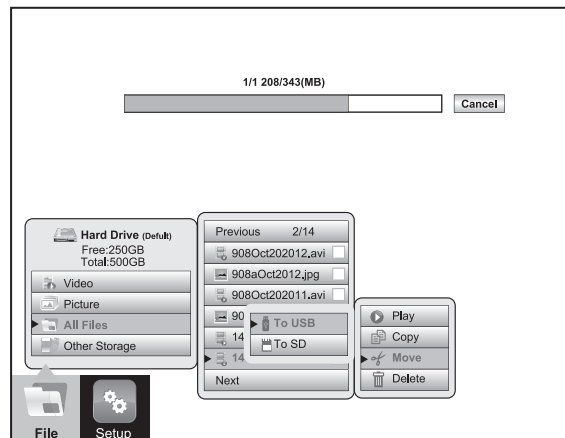

9. If deleting files use the **down ↓** arrow key to select **Delete** and press **Enter**.



WARNING

Do not remove the SD or USB device from the control module while copying or moving files to them. This may result in corrupt un-playable files being created and a risk of corrupting the original file on the hard drive.

5.5. File Format of SD Cards and USB Devices

The control module will recognize USB thumb drives and SD cards that are formatted in the FAT32 or NTFS file system and a maximum size of 64GB for SD cards and 128GB for USB thumb drives. If other file formats are used the control module will show an error message of “Not enough space on disk” when it is used to copy or move a file to it. The control module cannot read media in other formats but it does know that a USB or SD card is plugged in, so it perceives the SD or USB device as being full.

In the Windows operating system it is possible and common to have more than one type of disk drive. The most common are “Local” and “Removable” drives. SD and USB devices are in the “Removable” disk class. It is possible to convert a SD or USB device into a “bootable” drive and use it to run programs. When an SD or USB device is converted to a bootable disk it is now classified as a “Local” disk. The control module will work with removable disk but **not with a local disk**.

To check if your SD or USB device is a local disk or a removable disk plug it into any computer running any version of windows. Launch “My Computer” to see a screen similar to the illustration below. The illustration below shows the drives lettered C, E, and G as local disk. These will not work in the control module. The second line shows drive H as a removable disk which will work in the control module. If a disk is converted into a bootable disk it is not possible to convert it back to a format that will work in the control module.

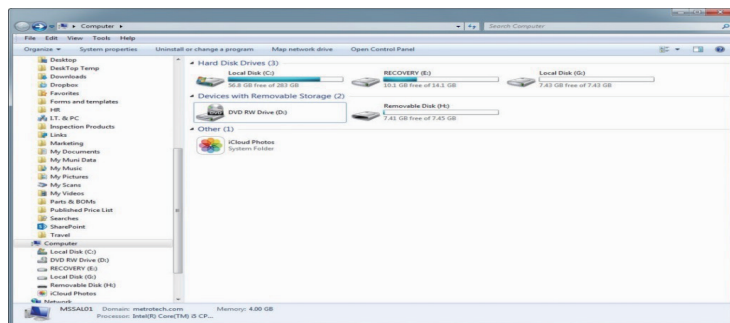

5.6. Troubleshooting Video Playback

If a file is copied or moved from the control module and will not play on a PC:

- Check to see if the file will play in the control module. If it will not play then the file may have been corrupted during the move or copy. Try and recopy the file again making sure not to interrupt the process until it is completely finished.

If a file copied or moved from will play in the control module but not play on a PC:

- Try a different media player on the PC and try a different PC. The AVI video format used by the control module is a Microsoft format and should play in the Windows Media Player with no issues. If the file is not playing or playing incorrectly there is a possibility that the correct video codec is missing. Computers running Windows 7 or Window 8 most likely will have this codec installed by default. It is possible that in older operating systems a codec may need to be installed. See section 5.8 Getting Codecs.

5.7. AVI Video Format

Audio Video Interleaved (aka Audio Video Interleave), known by its initials and file extension of **.avi**, is a multimedia container format introduced by Microsoft in 1992. AVI files can contain both audio and video data in a file container that allows synchronous audio-with-video playback. Because this file format was developed by Microsoft; the AVI video format will play in Microsoft’s Windows Media Player as well as other media players.

5.8. Getting Codecs

If an AVI video file will not play or plays as an audio file with video, it may be because you do not have the appropriate codecs installed on your computer. The video and audio tracks in a file have been “encoded” or “coded”, and must be “decoded” in the right way in order to play the file back. This is why a codec is needed (**Coder / Decoder**). A media player, such as **WMP (Windows Media Player)** may require a specific codecs to be installed in order to play a specific type of video file.

5 Video Recording and Picture Image Capture

When videos are transferred from the control module to a SD or USB device, a compressed folder is added to the SD or USB device containing software named “MediaPlayPlus”. Installing MediaPlayPlus to your Windows PC will add new features to Windows Media Player and add the codecs which are necessary to play the AVI file. Specific AVI codecs can also be downloaded from the DivX website at www.divx.com. When installing the DivX program it is recommended to choose “Custom Install” so that only the necessary components are installed.

5.9. File Associations

To make a certain type of file extension run with a default program each time a file association needs to be set in the windows operating system.

1. In “My Computer” or “File Explorer”, right mouse click on an AVI file.
2. Select “open with”.
3. Select Windows Media Player.

If Windows Media Player is not shown on the list of available software, you will have to select “Choose Default Program” in the bottom right corner. Select “Windows Media Player” here.

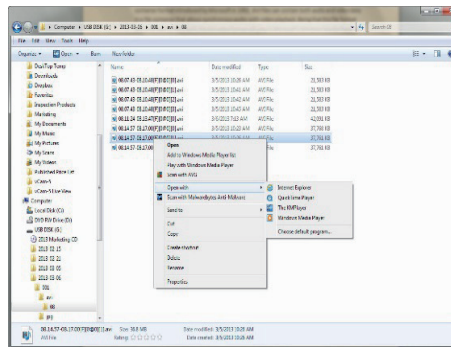

4. Make sure the “Always use the selected program to open this kind of file” box is checked. If “Windows Media Player” is not shown in the “Choose Default Program” choices then you will have to use the “browse” function to manually add the programs “executable” (.exe) file in “C:\Program Files”. This option requires an advanced knowledge of the Windows operating system.

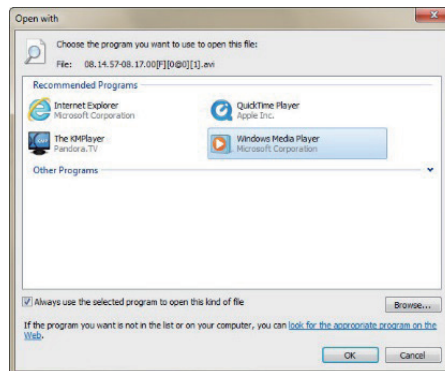

5. Consult your IT department or computer dealer if needed.

5.10. Other Media Players

There are several free video players available for download on the internet. These video players allow some advanced features that Windows Media Player may not have, such as playing several videos at the same time to compare them, and the ability to play multiple video formats. You can find these by doing an internet Search on “Video Players” or “AVI Video Players”.

A few of the more popular players are:

- The KM Player <http://www.kmpmedia.net/>
- VLC Player <http://www.videolan.org/>
- DivX Player <http://www.divx.com/>

NOTE

Vivax-Metrotech does not provide technical support for any of these players or Windows Media Player. Consult the manufacturer or your local IT department for technical support.



Vivax-Metrotech has manufactured the vCam-5 control module to produce video files and jpeg pictures that are compatible with the various Windows operating systems from Windows XP and later versions. Vivax-Metrotech cannot be responsible for the compatibility of all types of SD cards or USB drives. It is highly recommended that before these devices are purchased in bulk that they are tested for compatibility first.

Vivax-Metrotech cannot provide technical support for any of these devices, Windows Media Player, security and multi-media settings on computers. Consult the manufacturer or your local IT department for technical support on these items.

6. Features Available During Recording

During a video recording the following options are operational and usable:

- WiFi (see section 7, WiFi and Ethernet)
- Sonde (see section 11, Locating Sondes and Pushrod)
- Audio Commenting (see section 6.1, Voice Over)
- Full Text writer (see section 6.7, Text Writer)
- Camera LED control
- Distance counter reset
- F9 Display adjustments
- Take a JPEG image picture (section 5.3.2, JPEG Image Capture)
- Pause the video for up to 30 minutes (section 5.4, Play Video and View Pictures in the Control Module)
- Use the digital zoom to view close up (view only, the zoom effect will not be recorded)
- Pushrod tracing (section 11, Locating Sondes and Pushrod)

6.1. Voice Over

The voice over feature will add audio comments to the recorded video. The control module has an internal microphone located to the left of the microphone on/off button. An external microphone jack is located below the microphone on/off button. Use an external microphone when in a noisy area.



Microphone on/off button



Microphone on, icon shown on the status bar



Internal microphone



External microphone jack

1. Press the **Microphone** button on the front panel of the control module. When the microphone is on the button will glow red and the microphone icon will be shown on the screens status bar.
2. Speak clearly at a normal tone and volume towards the internal microphone labeled with an icon to the left of the microphone on/off button.
3. Stay at a distance between one and two feet from the internal microphone while speaking.
4. Press the **Microphone** button again to turn the microphone off.

6.2. Volume Control

During playback of recorded video the volume level can be adjusted.

Press and hold the **Ctrl** key then use – (dash) and + (plus) keys to lower and raise the playback volume. The volume status will appear at the bottom center of the screen while the changes are being made.

Press and hold the Ctrl key then use – (dash) and + (plus) to lower and raise the playback volume.



and + to raise playback volume



and – to lower playback volume

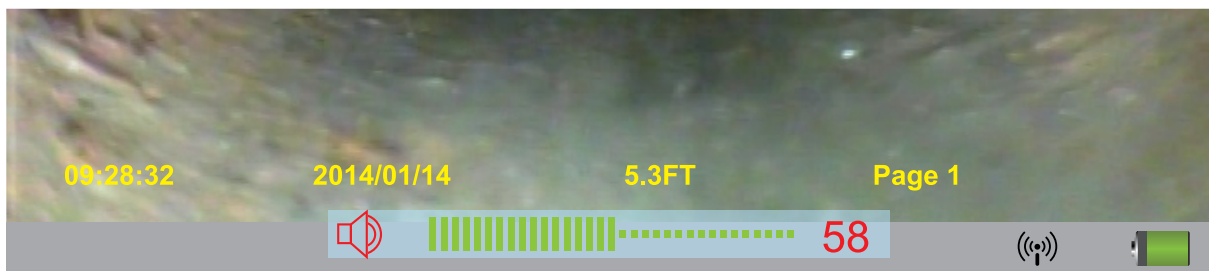

6.3. Display and Backlight Settings

At any time pressing the **F9 Display** key will bring up the color settings/backlight sub-menu.

1. Use the **up ↑** and **down ↓** arrow keys to move between the color settings selections.
2. Use the **left ←** and **right →** arrow keys to lower or raise the display settings.
3. Use the **left ←** and **right →** arrow keys to turn the backlight on or off. (Left is off and right is on.)
4. Press the **Enter** key to save the new display setting and exit the sub-menu.

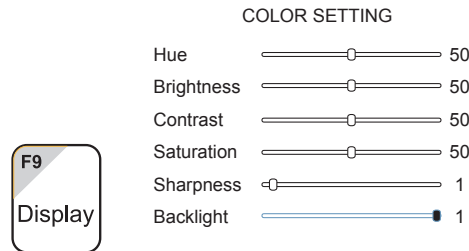

6.4. On-Screen Status Bar

The status bar shows the battery status and active features such as sonde, microphone and WiFi. The key combination of **Ctrl + F10** will hide the status bar. Use the same key combination to bring the status bar back.

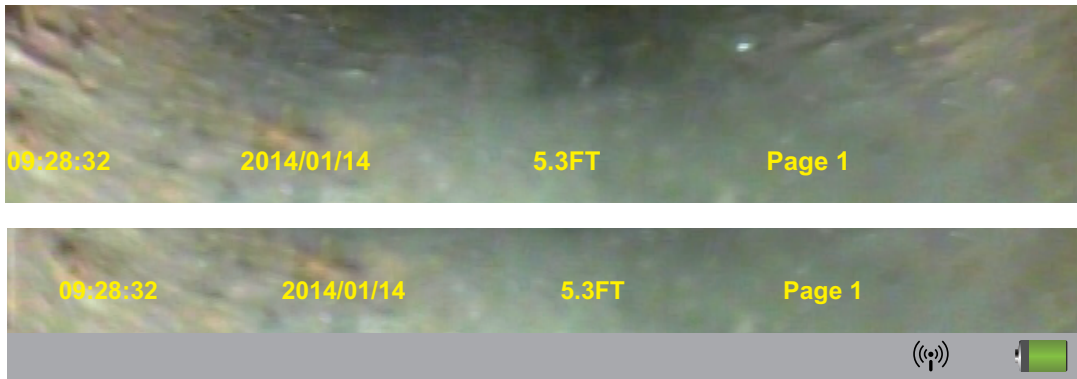

6.5. On-Screen Display (OSD Info)

The current time, date and distance of pushrod deployed and be shown on the screen and be recorded in videos and pictures. The color of the OSD info can also be changed to suite the environment inside the pipe being inspected. By default the OSD is positioned at the bottom of the screen and in white text.

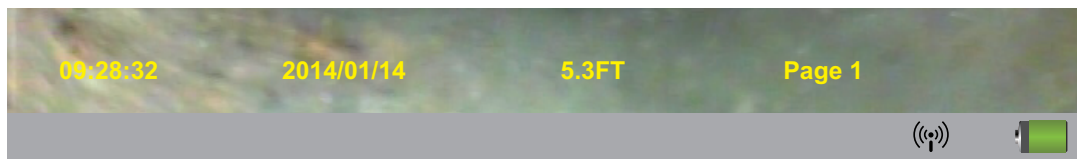

1. Press the **F2 Info** key once time to show the OSD at the bottom of the screen.
2. Press the **F2 Info** key again to move the OSD to the top of the screen.
3. Press the **F2 Info** key again to turn it off and remove from screen.
4. To change the color of the OSD press and hold the **Ctrl** key while pressing the **F2 Info** key to toggle through the available colors.

6.6. Camera LED Light Control

Use the camera LED Dimmer knob on the front panel to raise, lower or turn off the camera's LED lighting.



6.7. Text Writer

6.7.1. Introduction to the Text Writer

The Text Writer function allows users to add descriptive text and comments to recorded videos and pictures. The user can customize the text description being shown on the videos and pictures. The Text Writer has 20 pages with 14 lines and 30 characters per line per page to be saved and later recalled for use.

The content from the Text Writer is saved into memory so if the unit is turned off the text will still be available when turned on again.



NOTE





If the unit is reset to factory defaults the saved pages of text will be lost. If the CMOS battery on the DVR circuit board is removed all text will be lost. Only the text is saved into memory. Any colored text will be reset to the default color of white.

The ESC, F3, F4, F5, F6, F7, F8 and F11, Page Up and Page Down keys are related to using the Text Writer feature and covered in this section of this manual.

6.7.2. Keyboard Function Keys of the Text Writer



Fn Keys	Function	Description
	Clear text from screen	At any time press the ESC key to clear the Text Writer's text from the screen.
	Change OSD position and turn off	<p>F2 – Info (On Screen Display) – The On Screen Display shows the Date, Time and Distance set in the control module. This information will appear in videos and pictures.</p> <p>Pressing this key:</p> <ul style="list-style-type: none"> • Once will turn on and display at the bottom of the screen. • Twice will move it to the top of the screen. • 3 times will turn it off. <p>Ctrl + F2 – Change On Screen Display text colors - While holding down the Ctrl key, press the F2 Info key repeatedly to toggle through the colors of white, black, yellow and green.</p>
	Change Text Colors	<p>F3 – Text Color – Use the F3 Text key to change the text color from the default color of white, black, yellow and green.</p> <p>Ctrl + F3 – turn off/on Press and hold the Ctrl Key and press F3 to turn the text writer on and off. When the Text Writer is on, the current page number is shown on the bottom right of the screen. When turned off the page number is not shown.</p>
	Change Background Colors	F4 – Text Background – Use the F4 key to add a background color and toggle through the background colors of black, white, and grey.

	<p>Recall a saved page</p>	<p>F5 – Recall Page – Use the F5 Recall key to retrieve a saved page of text from memory. Press the F5 Recall key and a page number dialog box will appear in the bottom left section of the screen. Use the up and down arrow keys to scroll to the desired page to recall. When the number for the desired page to recall is shown press the enter key to complete the operation.</p>
	<p>Saves the current page of text</p>	<p>F6 – Save Page - Use this key to save the Text Writer's text into memory. When text is placed on the screen via the Text Writer, the page that contains the text can be saved into memory and be recalled for future use.</p>
	<p>Delete saved pages</p>	<p>F7 Delete Page – Use this key to delete a saved page of text. Recall the page or use the Page Up and Page Down keys to scroll to this page. While on this page press the F7 Delete key to complete the operation. NOTE: Deleted pages cannot be retrieved.</p>
	<p>Delete all saved pages</p>	<p>F8 - Delete All Pages – Use this key to delete all saved pages of text. Press the F8 key and a message will appear to confirm the deletion of all the pages. Use the left and right arrow keys to select OK to continue the process or cancel the process. NOTE: Deleted pages cannot be retrieved.</p>
	<p>Change Fonts</p>	<p>F11 – Font - Use this key to change the font type of the Text Writer text. Press repeatedly to scroll through five font types.</p>



TIP
Darker colors may work better in pipes with water running through them. The lights from the camera head may reflect in the water and white or yellow text may become washed out. Use a darker color and switch from light to dark when needed.



TIP
A background for the text created by the Text Writer can be used in situations where the images on the screen have lots of reflection and change often. Having a contrast in color from the text to the background will make the text stand out better.



TIP
Note that the page being recalled will be recalled into the current page displayed by the page number shown on the bottom right of the screen. Pressing the ESC key will clear the recalled text and recalling the page number shown on the screen into itself will bring back that text.





TIP
Use the Pause key on the top keypad to pause the video recording. With the video paused use the up and down arrow keys to scroll through the saved pages of text and stop at the desired page. With the desired text being shown un-pause the video to continue recording. At any time during the recording press the ESC key to clear the text from the screen.

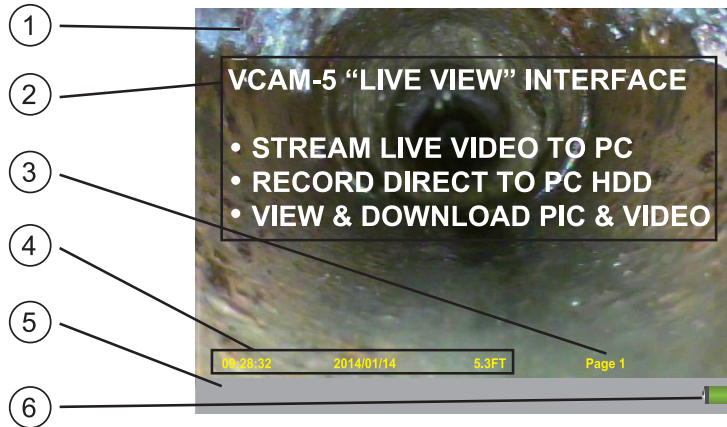

TIP
3rd party full version text editors and observation software (PACP and LACP) can be used with the control module through the RS232 socket and RCA composite sockets.

6.7.3. Text Writer Components

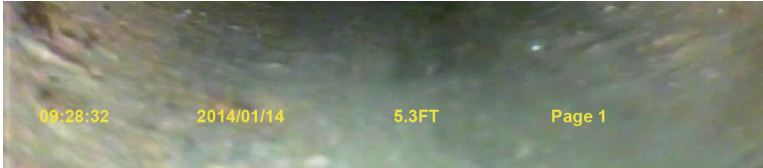

1.	Main viewing screen of the control module.
2.	Sample of the text from the Text Writer.
3.	Current Text Writer page number.
4.	On Screen Display of Time, Date and Distance Deployed.
5.	The Status Bar shows the battery status and active features such as sonde, microphone and WiFi. The key combination of Ctrl + F10 will hide the status bar. Use the same key combination to bring the status bar back. 
6.	Page recall dialog box will appear when the F5 Recall key is used to recall saved pages of text. Use the up and down arrow keys to scroll to the page number of the desired page to recall. 

6.8. JPEG Image Capture

Pictures will be saved to the default drive you selected in the initial control module setup screen. If no other drive is selected the pictures will be saved on the internal hard drive.

1. Press the **Picture Capture**  key on the top panel keypad.
2. The picture icon and picture file name will appear momentarily on the bottom left of status bar confirming that the picture was taken and saved.
3. Pictures can be taken from live video, while a recording is in progress, or from a video being played back in the control module.





TIP

Use the Text Writer feature to add identifying text to the recording video and image captures. Now while looking at the preview in the file list sub-menu the text recorded on the video and pictures will help identify the target video or picture.

6.9. Digital Zoom

Use the zoom feature while viewing live video, recorded video or jpeg captures.

1. Press the **Zoom**  button on top panel keypad to activate the zoom feature and bring up the red zoom control box on the screen.
2. Move the zoom box  with the arrow keys to the area to be magnified and press the **Enter** key.

While the zoom box is shown press up to three times more to increase the digital zoom level. While using the zoom feature no other keys on the keyboard, top panel or front panel will be useable.

7. WiFi and Ethernet

7.1. WiFi Connection for Apps

The vCam-5 Control Module has a built in WiFi router that broadcasts an SSID (secure network name) and uses DHCP (the protocol that assigns an IP address needed to connect to the control module) to assign IP addresses to up to three devices at a time. When connected to the control module various apps can be used to stream live video from the control module into smart phones, tablets and PCs for use with various apps.

The video stream will include any text shown on the control module screen along with the on screen display showing the system time, date and distance out.

WiFi Connection Settings for Apps

While more information may be required by the apps manufacturer below we can list most of the basic information that will be needed.

IP address: 192.168.1.108

TCP port: 34567

Channel: 1

User name: Admin

App password: 12345678

vCam-5 direct connection password: 12345678

7.2. Ethernet Connection



The vCam-5 Control Module can connect to a desktop or laptop PC via the Ethernet Cross Talk cable which is included with the control module. "vCam Live View" is a web based program that is integrated into the control module. By an Ethernet connection this program can be accessed and used.

The Live View interface is a web-based program to stream live video into a computer so it can be recorded on the computer. Along with streaming video the hard drive of the control module can be accessed to download video and pictures files.

Live View Connection Settings



TIP

To directly connect to the control module, the laptop or PC must be using the DHCP protocol in order to be assigned an IP address from the control module. If the laptop or PC is using a static (assigned fixed) IP address it will need to be changed to DHCP in order to connect. The majority of personal laptops or PC's use DHCP. Static or fixed IP addressing may be found in large local area networks such as schools or large businesses. Consult with local computer staff for information on this.

7.2.1. Connect by Ethernet

Establishing connection to the control module by Ethernet (RJ45) cable, in Windows 7, 8, and Vista.

1. Turn the control module on and activate the WiFi by pressing the **F12 WiFi Key**.



2. Plug the supplied RJ45 Ethernet Cross Talk cable into the socket on the control module and into the computer's RJ45 port. The LED lights around both RJ45 sockets should start blink indicating a proper connection.

7 Wi-fi and Ethernet

3. Launch Internet Explorer web browser. Check that a direct connection to the vCam-5 Control Module is made by opening the “Network and Sharing Center” found in the system tray by the clock in the bottom right hand corner of your computer screen. Note that in the connection, your status will be listed as “limited access” or “no network access” and that you will have no internet access. Internet Explorer must be used. The interface will not work in other browsers.

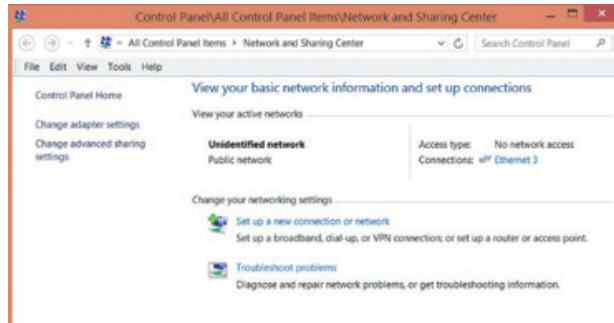

4. From the menu bar at the top of the page select **Tools**.

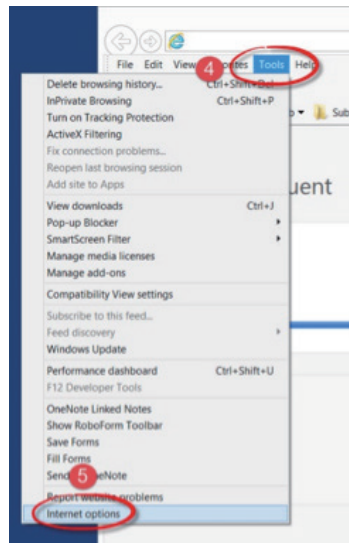

5. Now select **Internet Options**.
6. Now select the **Security Tab**.

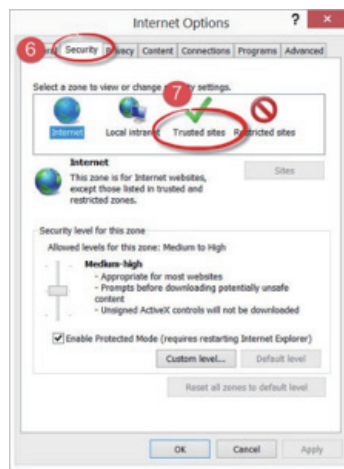

7 Wi-fi and Ethernet

7. Now select **Trusted Sites**.

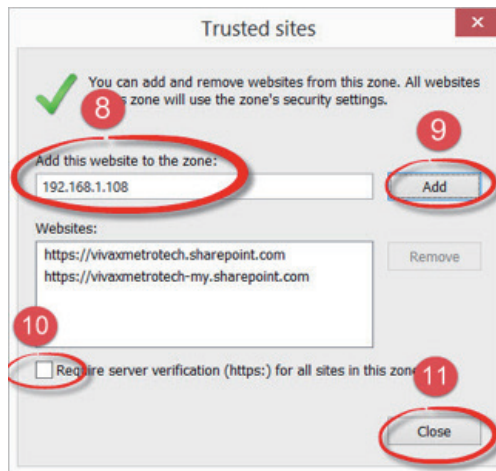

8. Type the control modules default IP address of 192.168.1.108 into the empty field and press the **Add** button to add the address as a trusted site. Do not type www. or http:// , type only the IP address and select **Add**.
9. If the box to "Require server verification (https:)" is checked, un-check it.
10. Close the trusted sites sub-menu and save the changes made by clicking on **Close**.
11. Return to Internet Explorer main page by clicking **OK** to close any other dialog boxes.
12. In the URL field located at the top of the page type in the control module's IP address of 192.168.1.108 and press **Enter**. Do not type in www. or http:// before the IP address. The Interface should start running now and you should see the camera feed in the browser.

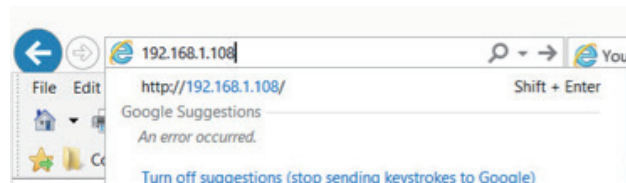

13. Depending on the browser's security settings a dialog box may pop up with a message to let the "ActiveX controls and application run and install". If this message appears, the ActiveX settings will need to be changed in the browser. To change the ActiveX settings, return to the Security Settings by following the previous steps of 5 through 9. Now at the bottom click on **Custom Level** to access the ActiveX settings.

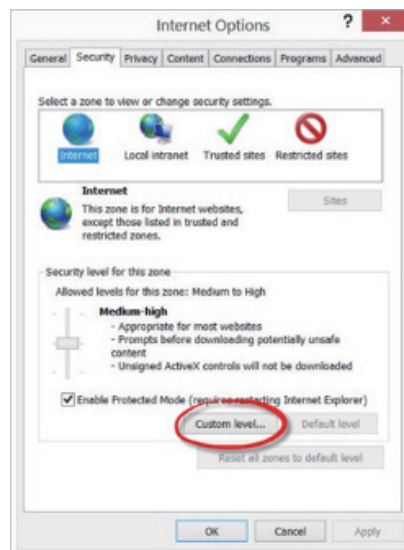

7 Wi-fi and Ethernet

14. Scroll down to the **ActiveX controls and plug-ins** section and make the following changes:

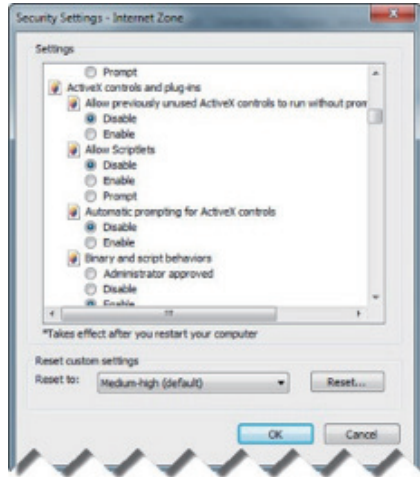

Description of Setting	Change Setting to
Allow Scriptlets	Enable
Automatic prompting for ActiveX controls	Enable
Initialize and script ActiveX controls not marked as safe for scripting	Enable
Run ActiveX controls and plug-ins	Enable
Script ActiveX controls marked safe for scripting	Enable
Download signed ActiveX controls	Enable
Download unsigned ActiveX controls	Enable

15. Select **OK** to return to the previous custom setting window.

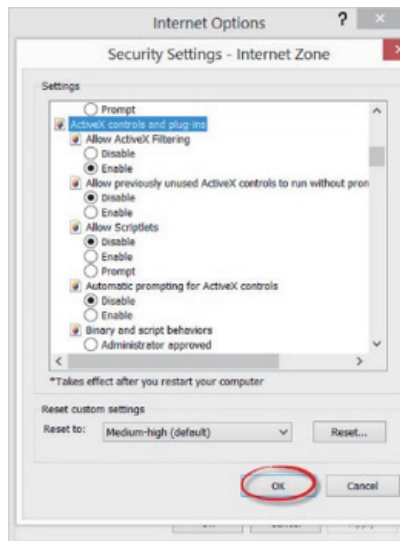

16. Select **OK** to return to the browser program.

17. Repeat step 12 to launch the interface.

7.3. Connect to a PC or Laptop by WiFi

The **Live View** interface is a web-based integration to stream live video into a computer so it can be recorded on the computer. Along with streaming video, the hard drive of the control module can be accessed to download and view video and pictures files.

7.3.1. Connect the Control Module to a Laptop or PC

1. Activate the WiFi feature in the control module by pressing the **F12 WiFi** Key. Make a note of the SSID (vCam-5 followed by the last 6 digits of the control module's serial number located on the back of the unit). When the WiFi is active there will be a WiFi symbol on the bottom right of the control module screen.



2. Launch the "View List of Available Wireless Networks" screen in on the computer's desktop. (In most versions of Windows this is found on the bottom right of the screen by the clock.)
3. Find the SSID vCam5 followed by the last 6 digits of the serial number of the control module and select it to connect.



4. Enter the default password of 1234568 when prompted.
5. When connected run the steps in section 7.21 to setup the browser interface if needed.

NOTE



To directly connect to the control module, the laptop or PC must be using the DHCP protocol in order to be assigned an IP address from the control module. If the laptop or PC is using a static (assigned or fixed) IP address it will need to be changed to DHCP in order to connect. The majority of personal laptops or PC's use DHCP. Static or fixed IP addressing may be found in large local area networks such as schools or large businesses. Consult with local computer staff for information on this.

7.3.2. Internet Explorer "Live View" Browser Interface

After establishing a connection between the control module and computer, these features are available in the interface.

- Stream live video to computer
- View pictures in the control module
- Record video direct to the computer
- Take snapshots directly to the computer
- Playback recorded videos in the control module
- Download files from the control module's hard drive

“Live View” Browser Interface Main Screen

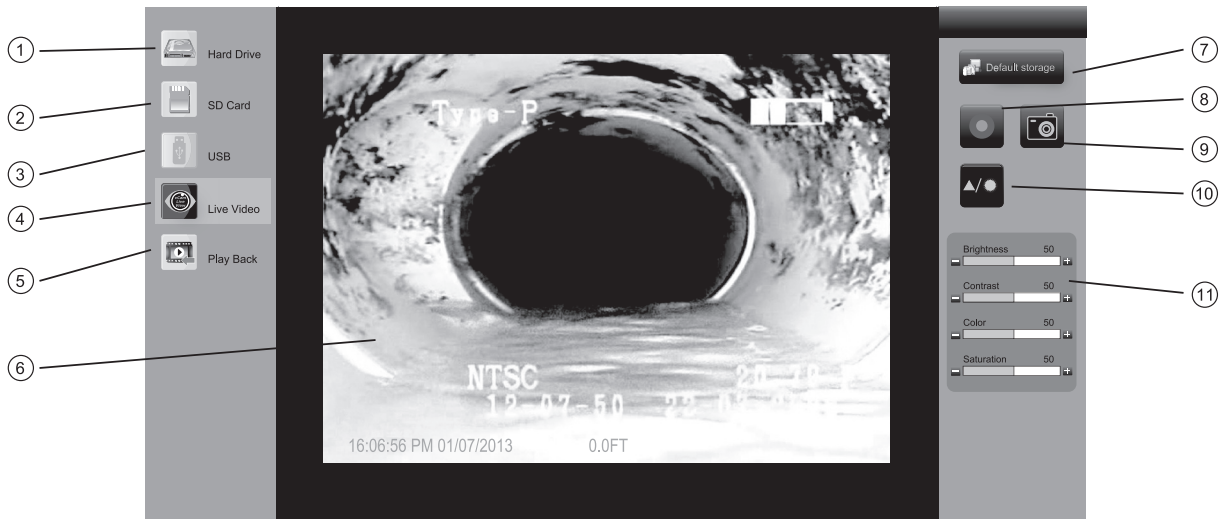

1.	Hard drive access	Press this icon to view the list of files on the control module.
2.	SD Card access	Press this icon to access files on the SD card in the control module.
3.	USB Drive access	Press this icon to access files on the USB Drive in the control module.
4.	Live video access	Press this icon to view the video stream from the control module.
5.	Video Playback	Press this icon to watch videos from the control module.
6.	Main screen	The main screen to watch the live video from the control module.
7.	Set default storage	Press this icon to set the folder where files are saved to when recording direct on a laptop or PC.
8.	Record video	Press this icon to start the video recording session.
9.	Capture image	Press this icon to take JPEG pictures from the live video.
10.	Screen color controls	Press to launch the laptop or PC screen settings.
11.	Screen color dialog box	Use this to adjust the computer's LCDs brightness, contrast, color and saturation.



NOTE

The changes made to the LCD screen settings will also be reflected in both pictures and videos being recorded.

“Live View” Browser Interface File Access Screen

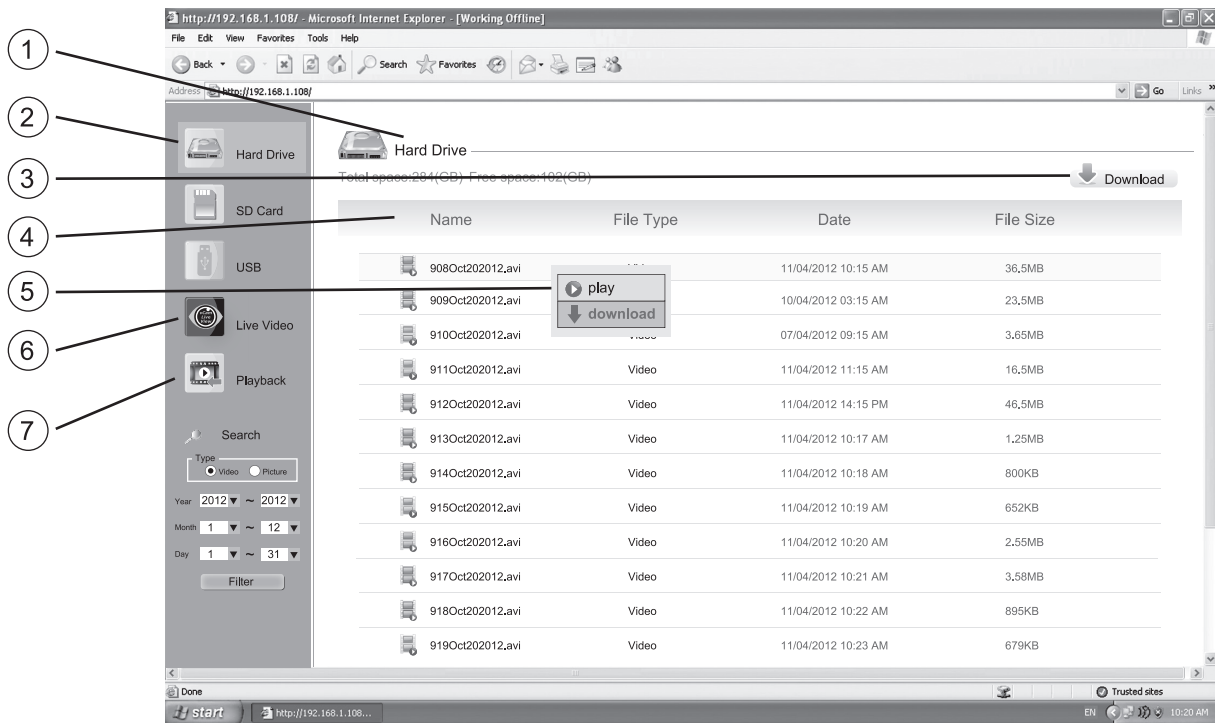

1.	Hard Drive Access	Press this icon to access the control module’s hard drive.
2.	Hard Drive Info	A view of the hard drive’s total size and remaining free space.
3.	Show Files	Click this icon to refresh the file list shown in item 4.
4.	Title Bar	Titles for file list; File name, type (video or picture), date, time and size in MB.
5.	Right Click Sub- menu	Right mouse click on a file to bring up this sub-menu. Select play to view the file or download to save it to the computer.
6.	View Live Video	Click to move back to the main screen with the live video feed.
7.	Video Playback	Click to launch video player to play the videos stored on the computer’s hard drive.

8. Cable Reels

8.1. Cable Reel Overview

8.1.1. Pushrod Cable

The Pushrod Cable used on both reels is constructed of a fiberglass rod surrounded by wire conductors and a Kevlar braid, all of which are coated with a thick polypropylene jacket. Because of the harsh environment the pushrod is used in, care should be taken to keep it in good operating condition.

Check Pushrod for Wear - Visually inspect the pushrod for cuts, kinks and abrasions as it is retrieved back into the cable cage. If the jacket is cut or worn to the point that the yellow or white Kevlar braid can be seen, then it is time to replace the pushrod. Using the pushrod with open cuts will result in water and moisture entering the pushrod and eventually travelling through it, causing a degraded camera image, or total image failure.

The pushrod shown below is an example of a badly worn jacket. This pushrod should be replaced as soon as possible.



Clean debris from the Cable Guide – Keeping the rollers on the cable guide will prolong the life of it and prevent the pushrod from rubbing against a surface that is not moving. Check the sides of the Cable Guide and clean any accumulated dirt and debris from its surrounding area. Periodically remove the roller and clean any dirt that may have deposited under it.

Keep the Pushrod and Termination Spring Assembly dry and clean – When retrieving the pushrod keep a clean dry rag in one hand and wipe down the pushrod as it moves through it. At the end of the day use low pressure water to rinse off the camera head and rinse away accumulated dirt and debris that may be caught in the spring. Shake dry or use low-pressure air to blow the excess water away and dry off the parts. The Camera Head, Pushrod and Termination Parts are exposed to very harsh chemicals in day-to-day use. Keeping a clean system will help prolong the life of these parts.

Maintain proper control of the Pushrod – Attempting to pull the pushrod out of the reel while the reel is locked will result in the pushrod collapsing in the reel and stressing the pushrod. Pushing the pushrod back into the reel while it is locked may cause the reel to tip over or kink the cable.

Rinse off the termination parts before the end of the day – The camera and pushrod are subjected to a very harsh environment with possibly very caustic chemicals. If the parts are not cleaned off and allowed to dry after use it may prematurely wear on these parts. Use low-pressure water to rinse out the termination spring parts. Wipe dry or use air to blow off the water before storing for the night or long periods. It is a good practice to remove the skid when storing to prevent water from drying between the skid and camera head.

8.1.2. Using the Cable Reels



WARNING

Do not use the control module as a handle to move the reel. Remove the control module or use the handle of the reel to move the reel.



Correct



Incorrect

8.1.3. Mounting the Control Module.

1. Line up the four pins on the control module bottom to the slots in the reels mounting blocks.



2. Lower the control module into the mounting blocks.



3. Push the control module backward until locked into place.



4. Unspool enough of the interconnect cable from the reel to allow its plug to reach the socket on the control module. Be aware of any excess cable around the cable cage that may become tangled when the cage starts spinning. Use the Velcro strap attached to the interconnect cable to secure the cable in place.

8 Cable Reels



5. Plug the interconnect cable into the control modules bottom socket.
This is a keyed plug and socket so be sure to line up the red dot on the interconnect cable plug to the same red dot on the interconnect socket on the control module.

- a. Pull back the knurled ring on the plug.



- b. Line up the red dot on the interconnect cable plug with the red dot on the control module's socket. Insert the plug into the socket and release the knurled ring.



- c. Check that the connection is secure by giving a slight wiggle and tug.
- d. To remove the interconnect cable pull back the knurled ring and pull the plug out.



WARNING

When securing the interconnect cable slack do not leave the angle of the cable from the socket at a sharp bend. Leave some slack in the cable to prevent any broken internal wires where the cable meets the connector.



8.1.4. Remove the Control Module

Press and hold down the locking tab to release the locking mechanism. With the locking tab held down use an upward and forward motion at the same time to lift the control module out of the mounting brackets.



8.1.5. Deployment of the Pushrod Cable



WARNING

The friction brake should always be partially applied to slow down cable deployment. To avoid injury, great care should be taken when stopping the cable from unwinding.

Do not wear loose clothing that can become caught in a spinning reel. Keep hands away from a spinning reel.

1. Position the reel on a flat surface approximately three to six feet or one to two meters from the entry point. This will provide enough space to work with the pushrod without a lot of slack dragging on the ground. Use the friction brake to slow down the movement of the cable cage if needed. Using the reel in a horizontal position makes the width between the feet greater. This will give the reel more stability if on uneven surfaces and will lower the height when in confined spaces.
2. Unlock the cable cage and loosen the friction brake so that the cable cage can spin.

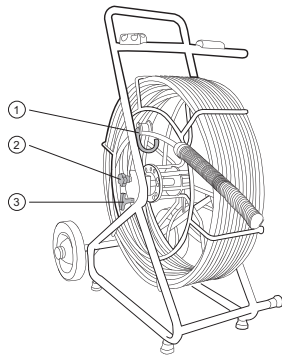

Type-CP Standard Reel

1	Cable Guide
2	Locking Brake
3	Friction Brake

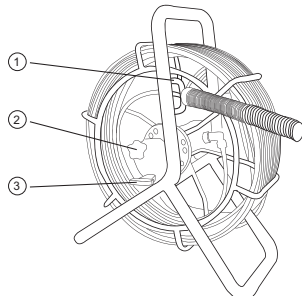

Type-M2 Mini Reel

1	Cable Guide
2	Locking Brake
3	Friction Brake

3. Turn the cable cage forward (clockwise) until the camera head is approximately at 9 o'clock position.
4. Pull the termination spring out of the cage and enough of the pushrod through the cage opening to thread the pushrod into the cable guide.
5. The reel is now ready to be deployed into the pipe.



TIP

Before deploying the pushrod you should:

- a) **Remove standing water from the pipe before inspecting. Inspection cameras are used to inspect pipes and the images will be much better if the camera head is not underwater.**
- b) **Remove debris and objects from the pipe first. The camera is made to inspect the insides of pipes and not to clean them or unblock them.**

Use the Insertion Sleeve as much as possible to prevent the pushrod from rubbing on sharp surfaces. Use devices such as a Tiger Tail when the point of entry makes it impossible to use the Insertion Sleeve such as inspecting lines in a manhole.



Insert Sleeve



Insert Sleeve in cleanout



Tiger tail used on a manhole

Use "grip" type rubber gloves to get a better grasp while pushing and to protect your hands from sludge during retrieval. The gripping action of the gloves will help keep a good hold on the pushrod while deploying.

Apply the pushing force to the pushrod as close to the point of entry as possible. Having excess pushrod between the point of entry and while pushing could result in kinking the pushrod. Never stand to use your weight to push on the pushrod. This may cause the pushrod to kink.



Proper placement and pushing force



Improper placement and pushing may result in kinking the pushrod.

Use finesse and not force when needed. The camera and pushrod are made to travel through multiple bends within reason. If having trouble navigating through the pipe try and pull the camera back four to eight inches and give it a quick push through. Sometimes the quick pushing motion will push the camera and termination through a tight area. Never pull the camera head back and repeatedly ram it into the pipe in an attempt to get through.

Run water in the pipe while inspecting. Inspect downstream with water running to lessen the friction in the pipe and to wash away dirt that may collect on the camera lens.

When having difficulties pushing, it may be better to do the recording on the way back, so that the video recording does not waste time showing a navigation through difficult areas. Record during the pull back and use even slow strokes to pull back the pushrod.

8 Cable Reels

When accessing a "T" entry use a string to bend lift the camera head and point it in the desired direction in the T. Be extra careful in T entries not to fold the camera back on itself; this could cause the camera to get stuck in the pipe.

Be sure to use the correct model camera in the correct size pipe. Using a camera that is too big may cause it to get stuck; using a camera that is too small will result in poor lighting and video quality.

Use a skid on the camera head. A skid will not only protect the camera head from directly hitting debris and offsets, it will also keep the camera head off the floor of the pipe and better centered within it. Keeping the camera head off the floor of the pipe will also improve the picture quality, because the light from the camera will be more evenly spread in the pipe. Various types of skids are available for different applications. See the section of this manual which covers accessories or visit our website for more skid information.



With no skid the camera head sits on the floor of the pipe. The camera head comes into contact with silt and debris in the pipe.

Using a skid lifts the camera head up off of the floor to help avoid silt and debris on the pipe floor.

Specialty skids like the Type-B skid will allow the user to work in larger diameter pipes and also provide additional lighting.

When retrieving the pushrod take care and try to lay the rod in the cage in layers while wiping the rod free of water and debris.

9. Camera Heads and Terminations

9.1. Parts of the Camera Heads

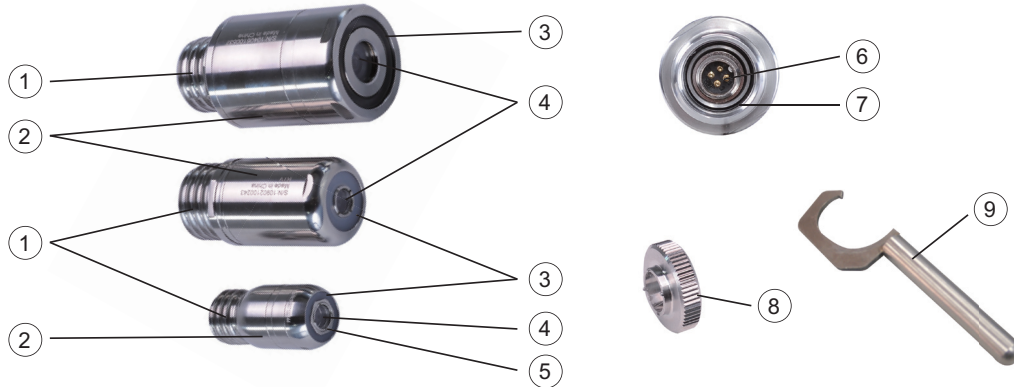

Cameras for the Type-CP and Type-M2 Reels

1.	Camera Base
2.	Camera Housing with serial number
3.	Polycarbonate LED Cover
4.	Glass Camera Lens
5.	Manual Focus Ring (D25 series only)
6.	4 Pin Male Plug
7.	Camera Base O-Ring
8.	D25 Series Focus Tool
9.	Camera Removal Tool

9.1.1. D25 Series Cameras with Manual Focus

The D25 camera series are manual focus by adjusting the clear camera lens. A focus tool ships with each D25 series camera.

1. Align the four male contact points of the focus tool with the four female points on the camera.



2. Press the tool into the camera's focus points and slowly turn the focus tool while monitoring the control module screen until the focus clarity desired is achieved.





9.1.2. Camera Head Options



The vCam series camera heads are available in a range of sizes for various applications. Choosing the proper camera depends on the diameter of the pipe to be inspected. The vCam-5 Control Module will sense the video format (PAL or NTSC) and automatically reset itself to work in that format.

All camera heads ship with a protective “standard skid” installed.

Camera Head Options for Standard Type-CP Reel

Camera Heads	Fits Reels	Description	Pipe Size Range
 <p>D34-C, Self-Leveling 34mm / 1.3" diameter</p>	Type-C Type-CP	D34-C NTSC (USA) D34-C PAL (EUROPE)	3 to 6 inches 75 to 200mm
 <p>D46-CP Self-Leveling 46mm / 1.8" diameter</p>	Type-C Type-CP	D46/SL-C NTSC (USA) D46/SL-C PAL (EUROPE)	3 to 8 inches 75 to 200mm
<p>Contact a local Vivax-Metrotech distributor or local office for ordering information, applications, compatibility and pricing.</p>			

Camera Head Options for Mini Type-M2 Reel

Camera Heads	Fits Reels	Description	Pipe Size Range
 <p>D25-M Non-Leveling 25mm / 1" diameter</p>	Type-M Type-M2	D25-M NTSC (USA) D25-M PAL (EUROPE)	2 to 3 inches 50 to 75mm
 <p>D34-M, Self-Leveling 34mm / 1.3" diameter</p>	Type-M Type-M2	D34-M NTSC (USA) D34-M PAL (NTSC)	3 to 4 inches 75 to 100mm
<p>Contact a local Vivax-Metrotech distributor or local office for ordering information, applications, compatibility and pricing.</p>			

9.2. Termination Parts

The Termination Assembly is comprised of the parts that connect the camera head on one end and are connected to the pushrod on the other.

The termination assembly will consist of:

- Spring
- Coiled Cable Assembly
- Lanyard Set

9.2.1. Spring

A hardened steel spring provides a flexible transition between the pushrod and camera head. The flexible spring also protects the coiled cable and lanyard set inside of it. The spring has a long length of tight coils in the rear (end closest to the pushrod), open coils towards the front and a short length of closed coils at the camera end. The Type-CP and Type-M2 springs at each end the spring ends at the “lead spring coil” which is used with the camera removal tool to remove the camera from the spring and the spring from the base.

The vCamMX spring is not removable by the user.

Type-CP Standard and Type-M2 Mini Termination Spring

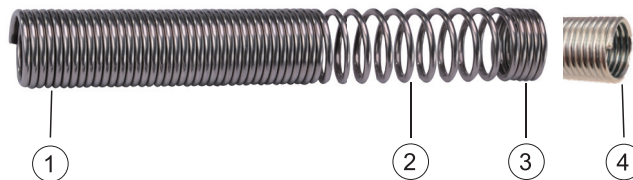

1.	Pushrod End
2.	Open Coils
3.	Camera End
4.	Lead Spring Coil

9.2.2. Coiled Cable Assembly

The coiled cable assembly is the electrical connection between the pushrod and camera head. The cable is coiled so that it can stretch without breaking as the spring moves through turns. Power for the camera lights and video signal run through this cable from the pushrod sonde compartment.

Termination Coiled Cable

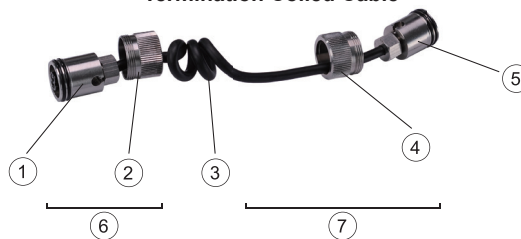

1.	Connector Base
2.	Floating Camera Nut
3.	Main Cable
4.	Floating Camera Nut
5.	Connector Base
6.	Rear (short pushrod end)
7.	Front (long camera end)

9 Camera Heads and Terminations

Connector Base Detail

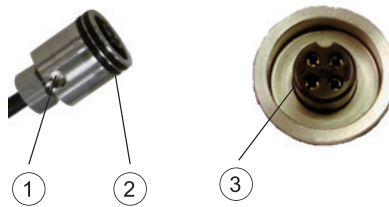

1.	Lanyard Slots
2.	O-Rings
3.	Keyed 4 Pin Camera Socket

9.2.3. Lanyard Set

The stainless steel set of lanyards within the spring attach the base of the termination by the pushrod to the camera head. These lanyards prevent the spring from over-extending when retrieving the camera.



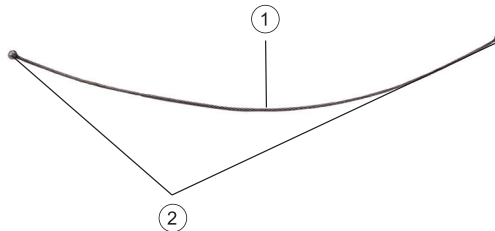

Steel Lanyard



1.	Wire Rope
2.	Retaining Ball

9.2.4. Termination Parts List

Picture	Description	Comments
	Camera Removal Tool	Comes with the control module
	Coiled Cord O-Ring, 17mm x 1.5mm	2 required at each end of the coiled cord assembly
	Camera Body O-Ring, 15mm x 1.5mm	Located in base of camera below 4 pin connector
	Coiled cable assembly, 12mm Standard	Fits D46 and D34-C cameras
	Coiled cable assembly, 12mm Short	Fits D46 and D34-C cameras
	Coiled cable assembly, 10mm Standard	Fits D34-M camera
	Coiled cable assembly, D25 Standard	Fits D25-M camera
	Dual D25/D34 Coiled cable assembly	Fits D34-M camera

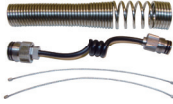
	Spring Kit, 12mm Standard (33mm dia. x 11-3/4" / 30cm long spring)	Kit includes a Spring, Coiled Cord Assembly and pair of Steel Lanyards
	Spring Kit, 12mm Short (33mm dia. x 7" / 18cm long spring)	Kit includes a Spring, Coiled Cord Assembly and pair of Steel Lanyards
	Spring Kit, 10mm Standard (1.1"8-1/4" / 22cm long spring)	Kit includes a Spring, Coiled Cord Assembly and pair of Steel Lanyards
	Spring Kit, D25 Standard (1" / 25mm dia. x 7" / 18cm long spring)	Kit includes a Spring, Coiled Cord Assembly and pair of Steel Lanyards
	Spring Kit, D25/D33 Dual (1" / 25mm dia. x 7" / 18cm long spring)	Kit includes a Spring, Coiled Cord Assembly, pair of Steel Lanyards and Camera Removal Tool
Contact a local Vivax-Metrotech distributor or local office for ordering information, applications, compatibility and pricing.		



NOTE

It is a good practice to keep a spare set of lanyards, a coiled cable and spring as a spare part at all times. These parts are field serviceable and can be changed in a matter of minutes while at a jobsite.

9.3. Removing the Camera Head

Tools needed: Camera Removal Tool (supplied with control module) an optional clamping or holding device, like a vise, would be helpful. Use only the tool provided to remove the camera head.

1. Clamp the pushrod into a vice at the base of the termination.



2. Position the "hook" part of the camera removal tool on top of the springs starting coil.



9 Camera Heads and Terminations

3. Hold the camera in one hand while using the camera removal tool to turn the spring starting coil clockwise. Continue this until the camera is loose enough to be removed by hand.



4. After the camera head is completely off of the spring, unscrew the floating camera nut from the base of the camera by turning it counter-clockwise.



5. Firmly grasp the connector base and carefully pull it out of the camera base.



6. Clean off any grease and debris from the o-rings at the base of the camera and connection plug if needed. Store the camera head in a clean dry place to prevent corrosion to any camera parts and prevent the pins from being damaged. If storing for long periods of time remove the skid from the camera head.



9.4. Removing the Termination Spring and Coiled Cable

Tools needed: Camera Removal Tool (supplied with control module) an optional clamping or holding device, like a vise, would be helpful. Use only the tool provided to remove the camera head.

1. Follow the instructions in section 9.3, Removing the Camera Head to first remove the camera.
2. Position the “hook” part of the camera removal tool on top of the spring’s starting coil.



3. Using the tool turn the spring counter clockwise until the spring is loose enough to be removed by hand. Completely remove the spring.



4. Un-screw the floating camera nut from the termination base.



5. Firmly grasp the connector base and pull it out of the termination base.

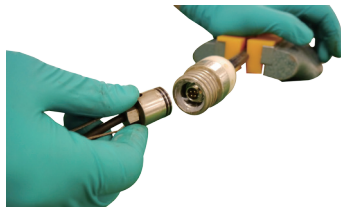

6. Clean off any grease and debris from the o-rings at the base of the camera and connection plug if needed. Store the camera head in a clean dry place to prevent corrosion to any camera parts and prevent the pins from being damaged. If storing for long periods of time remove any skids from the camera head.



9.5. Installing the Coiled Cable and Termination Spring

9.5.1. Pre-check the Termination Parts

Do a pre-check of the termination parts before installing them. Replace any parts if you have any doubts about them. Put all the parts together outside of the spring and use a control module attached to the reel to look for video and LED's lighting control. It is important that all the connectors, O-rings and threads be clean and free of debris between the threads.

9.5.2. Pre-checking Steel Lanyards

These lanyards prevent the spring from over-extending when retrieving the camera.

Check the lanyards for:

- **Steel Balls** - Check that the balls on the ends are secure, not deformed and show no signs of rust.
- **Wire rope** - Check for splinters, abrasions, kinks and signs of rust.



9.5.3. Pre-checking the Coiled Cable Assembly

The coiled cable assembly is the electrical connection between the pushrod and camera head. This is better checked while attached to the termination base and camera head.

Check the Coiled Cable for:

- **Jacketing** – Check that the jacket of the cable does not have any cuts or abrasions. When connected to a control module wiggle the cable at the base of the connections to check for hidden breaks in the cable.
- **Connectors** – Check that the plastic 4-pin connectors at each end are clean and in good condition.
- **O-rings** – Check the O-rings for wear, cuts and other damage. If dirty check for dirt under the O-rings.
- **Continuity** – Attach the coiled cable to the termination base and to a camera head. Attach the reel to a control module and power on. Check for video signal, LED lighting and lighting control.
- **Floating camera nuts** – Check that the threads on the floating camera nut are not damaged, are clean of dirt and the round shape is not deformed.



9.5.4. Pre-checking the Termination Spring

The termination spring provides a flexible transition between the pushrod and camera head.

Check the termination spring for:

- **Deformity** – Check that the spring is not deformed by having the outside coils not in line or that the spring has been stretched too far.
- **Lead coil** – Check that the lead coil is not bent, broken or protruding.
- **Rust** – Check that rust has not compromised the spring material.

9.6. Installing a Camera Head

9.6.1. Install the Coiled Cable and Termination Spring



NOTE

The lengths of the cable after the coiled part are different. One is longer than the other. The longer end gets attached to the camera while the shorter end get attached to the termination base.



ATTENTION

The 4-pin male plug and female socket used to mount the camera head “keyed” connectors. The keyed notch on the camera base must line up with the keyed groove in the coiled cable socket. Failure to align these keys together correctly will result in damage to the camera pins and coiled cable connector, or termination base connector.

When assembling the camera or coiled cable the control module should be powered off or interconnect lead un-plugged. Failure to do so may result in shorting out the camera head.

1. Clamp the pushrod into a vice at the base of the termination.

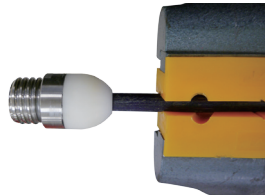

2. Clean the threads in the termination base then apply a liberal bead of silicone grease to the base female threads.



3. Feed the 2 lanyards through the floating camera nut and insert into the lanyard slots. Make sure that the lanyards are straight and not tangled in the coiled cable.

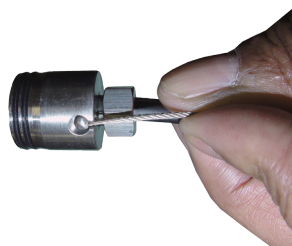

4. Pull the floating camera nut up and over the lanyards.





ATTENTION

The 4-pin male plug and female socket used to mount the camera head are “keyed” connectors. The keyed notch on the camera base must line up with the keyed groove in the coiled cable socket. Failure to align these key ways together correctly will result in damage to the camera pins and coiled cable connector, or termination base connector.

5. Line up the 4-pin female connector notch with the 4-pin male connector in the termination base.



6. Insert the coiled cable connector into the termination base. **Hand tighten only.** Do not use any tools to tighten this connection.



7. Feed the opposite end of the lanyards through the floating camera nut and insert into the opposite connector bases lanyard slots. Make sure that the lanyards are straight and not tangled in the coiled cable.
8. Pull the knurled camera nut up and over the lanyards.

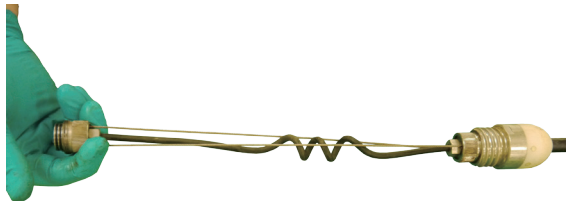

9. Wrap a piece of electrical tape around the floating camera nut securing the nut with lanyards to connector.

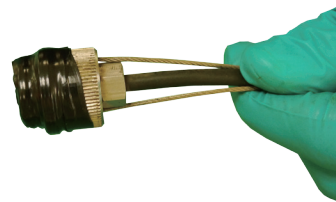

10. Slide the spring over the coiled cable assembly.



9 Camera Heads and Terminations

11. Screw the spring into the termination base. Hand tighten to termination, do not use any tools.



12. Pull enough of the coiled cable to work with to attach a camera head.



9.6.2. Pre-checking the Camera Head before Installing

If the occasion should arise where a camera head has to be re-installed or replaced, pre-check these items before the camera is fully installed. The visual checks can be done in an area with good lighting with the use of a magnifier. Some checks are better done with the camera LEDs turned on. For these checks you can use the camera test port, a camera test lead, or use the coiled cable plugged into the termination base of a reel which is connected to a powered on control module.

9.6.3. Pre-checking for Picture and LED Control

Visually check the 4-pin female connector on the camera and the 4-pin male connector on the coiled cable. Line up the keyed connector on the coiled cable to the camera head and attach them. Attach a reel to a control module and power it on. Through the control module check for an acceptable picture, that the LED lights on, the camera work and that you can control the LED lights. While still connected to the control module with picture showing wiggle the cable at the base of the connections to check for hidden breaks in the cable.

9.6.4. Pre-checking the Camera Base O-Ring

Visually check the O-ring for wear, cuts and deformation. Replace the O-ring if you have any doubts. Apply a bead of silicon based grease to the O-ring and the camera head's female base threads before installing the camera head.



9.6.5. Pre-checking the Camera Glass Lens and LED Cover

This pre-check is better done with a control module attached to a reel or by the camera test port. For this pre-check, the LED lights should be on so that the camera face can be better examined.

Pre-checking the LED Cover

The Polycarbonate LED cover is the section of the face of the camera that covers the LEDs. Visually check the inside and outside radius for chips and cracks.



Sapphire Glass Lens

The Sapphire Glass camera lens is the center clear glass section of the camera face. Visually check the outside radius for chips and cracks. Visually check the surface of the glass for scratches.

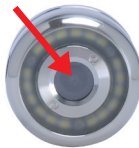

If you suspect that any cracks or chips may let moisture in, or if you suspect that scratches on the lens may affect the video quality, contact the factory or your local dealer.

9.6.6. Installing the Camera Head

After pre-checking the termination parts and camera head, the camera head is now ready to be installed.

The only materials needed are 1cc tube of a silicone based grease and a swab applicator. No tools should be used to install the camera head or termination parts. These require only hand tightening.

Use a dry rag if needed to better grip on the floating camera nut if there is a residue of grease around the area.



ATTENTION

The 4-pin male plug and female socket used to mount the camera head “keyed” connectors. The keyed notch on the camera base must line up with the keyed groove in the coiled cable socket. Failure to align these key ways together correctly will result in damage to the camera pins and coiled cable connector, or termination base connector.



ATTENTION

When assembling the camera or coiled cable the control module should be powered off or interconnect lead un-plugged. Failure to do so may result in shorting out the camera head.

1. Use a swab applicator to apply a bead of silicone grease on to the female threads in the camera base. Use a fingertip and apply a bead of silicone grease on top of the 2 o-rings on the coiled cable connector.

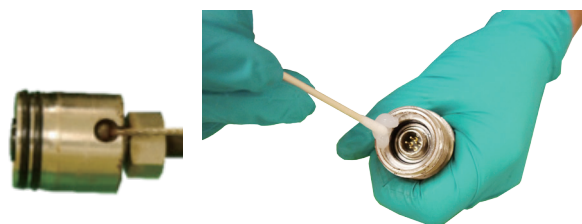

9 Camera Heads and Terminations

2. Feed the coiled cable with lanyards through the spring. Feed an amount that is comfortable to work with.



TIP

Use a nylon cable tie to compress some of the coils in the spring. This will give you a few inches of space to work in while attaching the camera.

3. Line up the keyway on the 4-pin male and female socket and plug and press the coiled cable connector into the camera head.



4. Pull up the floating camera nut to cover the lanyard mounting holes and screw the nut into the camera head. **Do not use any tools, hand tighten only.**



5. To prevent the lanyards from becoming twisted during installation of the camera head, first turn the camera attached to the cable assembly counter clockwise 7 complete turns. Now when screwing the camera head into the spring, the lanyards should not be twisted and wrapped around the coiled cable.



Screw the camera head clock-wise into the termination spring until it is flush with the spring. Hand tighten only.

10. Camera Skids

10.1. Camera Skids

Camera skids are devices that attach to the camera head to 1) keep the camera head off the floor of the pipe, to help avoid pushing up debris and dirt on which will end up on the camera's lens blocking your view, 2) allow the camera LED lighting to function better by keeping the lights more centered in the pipe allowing a more even spread of light on the pipe walls and ahead and 3) provide protection to the camera head by giving a shoveling effect which allows the camera head to be lifted over offsets and objects which helps prevent the camera head from making direct contact with them. And lastly the skids will help increase the pushing distance of the camera and pushrod by providing a more non-binding material to slide against plastic, clay, metal and cement pipes. There are a variety of skids for specific uses and camera sizes and few different methods of attaching the skids to the camera system.

The skid installation types are:

- **Setscrew:** Set screw mount screws are usually three set screws on the walls or base of the skid. The skids are fastened to the camera by tightening the set screws into the camera housing. These types of skids are referred to as "standard skids" and are usually supplied with a new camera.
- **Guide Skid:** Clamp-around skids slide onto the camera head and are then tightened in a clamp type configuration. These skids are referred to as "Guide Skids".

10.2. Skid Installations

There are two different installation methods for camera skids: "Setscrews" which tighten into the side of the camera housing and "clamp on" which clamp around the camera housing.

10.2.1. Standard Skid Installation

The standard skids ship installed on the camera head.

Tools Needed: two or three millimeter hex key or flat screwdriver, depending on skid model.

1. Use the hex key or screwdriver back out the three screws so that the camera head will slide un-obstructed into the skid.

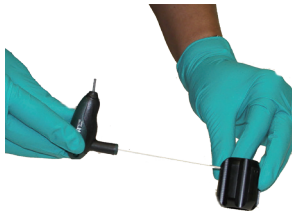

2. Slide the camera head into the skid until the head is flush with the front of the skid.



3. Use a hex key or screwdriver to secure the skid to the camera head.





NOTE

Do not over tighten the setscrews. This may result in stripping the screw threads or damage to the camera housing.



TIP

Apply a layer of electrical tape over the screw holes on the installed skid. This will help keep debris and soil out of the screw slots making it easier to remove.



10.2.2. Guide Skid Installation

Tools Needed: Hex key

1. Use a hex key and loosen the screws so that the skid will slide un-obstructed onto the camera head.



2. Slide the camera head into the skid until the head is flush with the front of the skid.

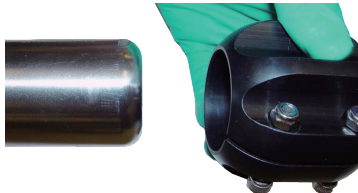

3. Use a hex key to secure the skid to the camera head.



NOTE

Do not over tighten the setscrews. This may result in damage to the camera housing.

10.2.3. Removable Rubber Guard Skids

Some of the vCam series skids will come with a removable rubber front guard. The removable rubber front is meant to protect the camera it should make direct contact with objects such as offsets. Over time the rubber guard will wear and then it can be replaced with a new rubber front guard. Follow these directions to change the rubber front guard.

1. Remove the skid from the camera.



2. With two fingers squeeze the rubber front guard as shown and pull it free of the skid.



3. Follow the same procedure to install a fresh one.

10.2.4. Type-B Adjustable Skid

Type-B skid is used to keep the camera head centered in pipes and off the floor avoiding debris and obstructions. The Type-B skid has adjustable settings for use in pipe diameters from 8" to 15". When the skid is completely collapsed it can be used in 8" pipes.

The Type-B skid will work with the D46 series cameras attached to a 12mm termination spring. This adjustable skid works best in straight run applications such as running from manhole to manhole.

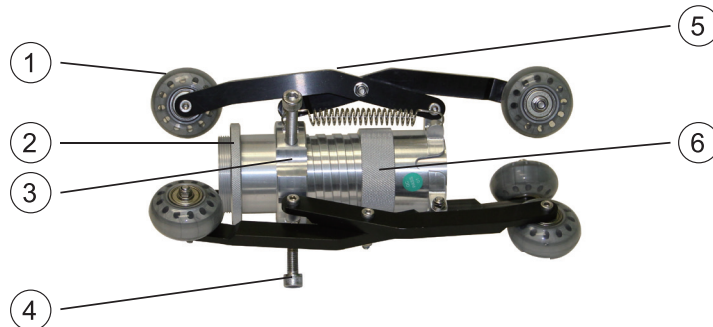

1.	Roller Wheels.
2.	Height Adjusting Arms.
3.	Diameter Adjustment Nut – Turn this nut to lock the skid at the desired diameter setting.
4.	Light Kit Grooves – The accessory light kit is installed in these grooves.
5.	Light Kit Mounting Nut – Used to secure the accessory light kit onto the skid.
6.	Socket Head Cap Screws – Used to hold the skid in place.

10.2.5. Type-B Skid Installation

Tools needed: Hex Key to remove standard skid and 8mm Hex Key to secure into.

1. Use a hex key or screwdriver to remove the standard skid from the D46 series camera. If using a D34 series camera leave the standard skid on to act as an adapter to take up the empty space in the Type-B skid.

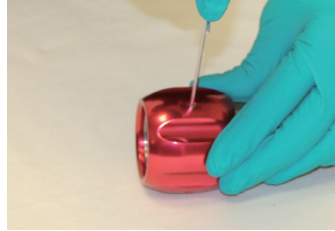

2. Slide the camera head into the Type-B skid until the head is flush with the front of the skid.

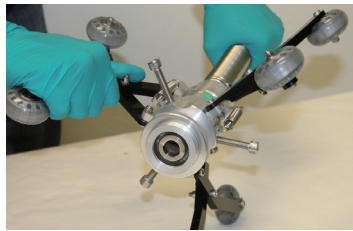

3. Use an 8mm hex key to secure the skid to the camera head.



NOTE

Do not over tighten the setscrews. This may result in damage to the camera housing.

10.2.6. Type-B Light Kit

The Light Kit attaches to the skid to provide additional lighting in larger diameter pipes. The light kit is powered by 3 AA Alkaline batteries and provide 20 hours of intermittent life.

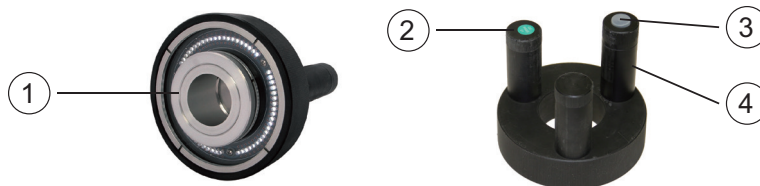

1.	Light Kit Mounting Nut	Screws into the skid body to keep the light in place.
2.	Battery Cap	Unscrews to allow the battery installation.
3.	On/Off Switch	To turn the lights on and off.
4.	Battery Tube	Holds the three AA Alkaline batteries.

10.2.7. Type-B Light Kit Installation

1. Remove battery caps and on/off switch.
2. Insert three fresh AA alkaline batteries, positive end first into battery tubes.
3. Replace the battery caps and on/off switch.

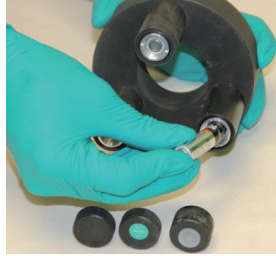

4. Align light kit battery tubes with light kit grooves on skid.

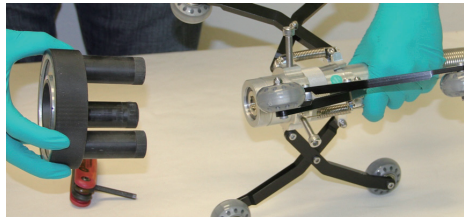

5. Apply even pressure to push the light kit into place.

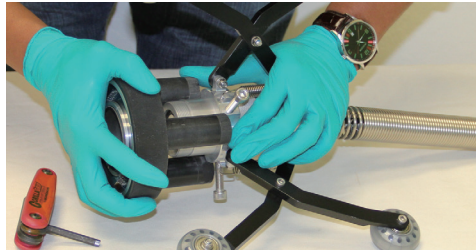

6. Hand tighten the light kit mounting nut.

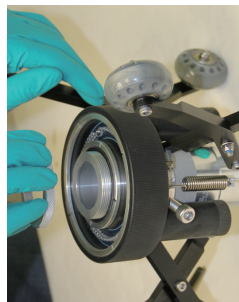

11. Locating Sondes and Pushrod

11.1. Introduction

All vCam series reels include a locatable sonde located at the base of the spring termination assembly. The controls for the sonde are located on the front panel of the control module.

The latest version Type-CP reel includes the option to trace the entire length of pushrod. This reel is easily identifiable by the post located on the counter block assembly. With this series reel, a utility locator's transmitter is used externally to send a locate signal through the length of the pushrod.

Vivax-Metrotech manufactures a range of utility locators and sonde locators. This manual will give a brief review of how to use the vLocCam2 and VM-540 Sonde Locators. Information on these locators can be found on our website or contact your local distributor for more information.

11.2. Applying a Locate Signal onto the Pushrod

A utility locator transmitter is required to locate the pushrod. Frequencies starting at 33kHz and above will work better than lower frequencies. This section applies to the Type-CP reel only.

1. Lock the cable cage by using the brake lock.
2. Connect the red colored hot lead from the transmitter to the contact post on the Type-CP reel.



3. Place the utility locator transmitter:
 - a) Out of the reel's general work area.
 - b) To prevent the leads of the transmitter from becoming tangled in the spinning reel cage.
 - c) So that the leads from the transmitter are not crossing earth over the path of the pushrod in the pipe.
4. Insert the transmitter's ground stake in earth approximately five feet at a right angle to the reel.



5. Turn on the utility locator transmitter and select a frequency. We recommend using a higher frequency such as 33 kHz, 65 kHz or 83 kHz. Insure that the transmitter has a good ground. The better the ground the better the locator will perform.
6. Use the utility locator in the line mode, not sonde mode to trace the path of the pushrod underground.



IMPORTANT

Always “Call Before You Dig” and follow your own company’s safety practices.
Always follow local, state and national regulations.

Sonde Locating

The best practice for locating the camera sonde is to push the camera into the pipe and when it is level stop and do the locate. From this point on work in 10 to 20 foot increments stopping every 10 to 20 feet and locate the sonde. It is not a good practice to just push the camera into the pipe a great distance away and set out to locate it. The distance counter in the control module may give an estimate as to how far the camera has been deployed but this is just for reference.

11.3. The vLocCam2 Sonde and Camera Locator

vLocCam2 Receiver Display

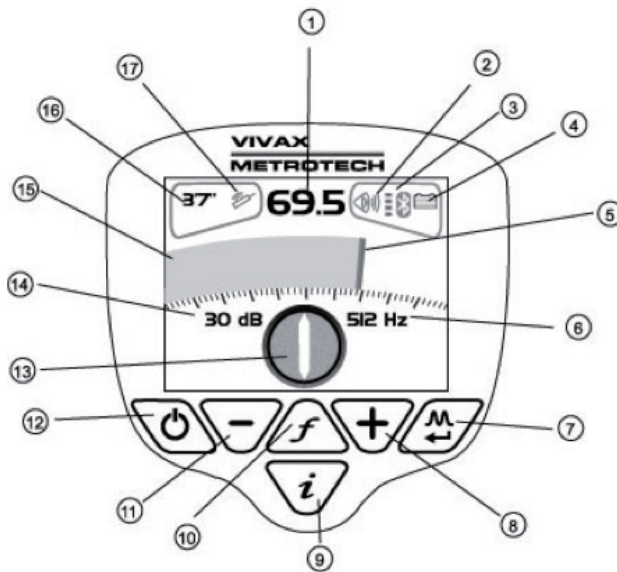

1.	Numeric Digital Display of Signal Response	10.	Frequency Select
2.	Loudspeaker Status	11.	Gain Control (reduce gain)
3.	Bluetooth and GPS Signal Quality	12.	On/Off Control
4.	Alkaline/Rechargeable Battery Status*	13.	Compass Direction Indicator
5.	Peak Signal Indication Bar Graph	14.	Gain Setting in dB
6.	Frequency Selected	15.	Analogue Display of Signal Response
7.	Location Mode Select	16.	Continuous Depth Reading
8.	Gain Control (increase gain)	17.	Location Mode (Sonde, Power or Radio)
9.	Information Depth/Current Measurement		

* Care should be taken when charging batteries – Only use the battery charger supplied with the control module. Cease charging if the batteries or charger become excessively hot.

11.4. Locating with the vLocCam2

Sonde Operation

On the vCam-5 control module turn on the sonde by pressing the Sonde button found on the control module front panel. When the sonde is active the sonde button will glow green and an icon will appear on the screen along with the frequency that the sonde is transmitting.

Locating the Sonde

1. Switch on the vLocCam2 and use the “f” pushbutton to select the frequency matching the sonde.
2. Check the distance reading on the counter of the vCam-5 control module and start the search for a signal approximately 10m before the suspected position of the camera head.
3. Hold the receiver as per the illustration to the right, with the display pointing across the suspected line of the camera head. Press the “+” pushbutton on the receiver. The display will show approximately 50%. Do not be concerned at this stage if the receiver is displaying an unstable signal, this is probably because the signal is very weak.

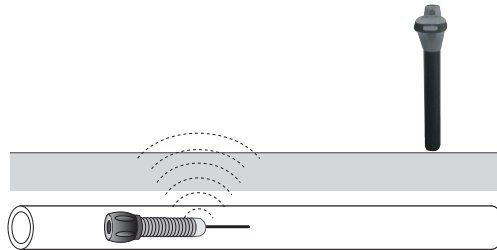

4. Walk along the suspected route of the camera. As the position is neared the signal will stabilise and increase so it may be necessary to press the “-” pushbutton to keep the signal strength within the display graph.
5. The signal strength will increase and decrease as shown. Pay particular attention to the three peak signals. The center peak is the biggest and shows the correct position along the line of the camera head.

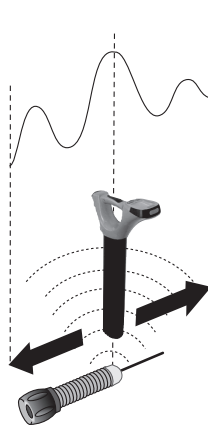

6. Now, keeping the receiver in the same orientation, walk across the suspected position of the camera head. The biggest signal will show the correct position across the line of the camera head.

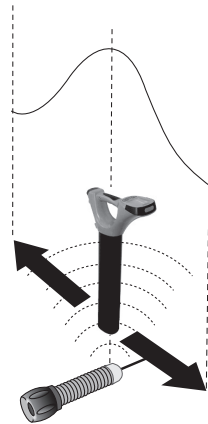

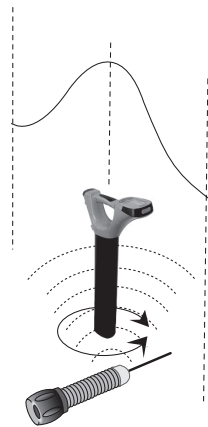

7. Finally rotate the vLocCam2 receiver to detect the biggest signal again. The vLocCam2 is now directly over the camera head and the display precisely across the direction the camera is pointing



Taking a Depth Reading

Locate the precise position of the camera head as instructed above. Place the vLocCam2 on the ground and press the “i” pushbutton, then the depth is displayed.

LAT 31° 10 48.816" N

LONG 121° 23 57.720" E

3'7"



17.2mA

LOG 085

Press + to log

11.5. VM-540 Sonde and Camera Locator



VM-540 Receiver Display

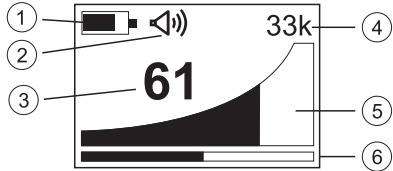

1.	Battery Level Indicator
2.	Speaker Volume Indicator
3.	Signal Strength Percentage
4.	Selected Sonde Frequency
5.	Signal Strength Indicator
6.	Sensitivity Setting Indicator

VM-540 Receiver Controls

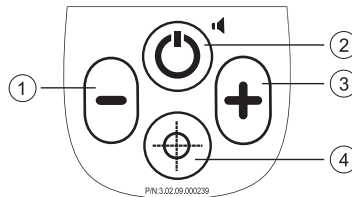

1.	Reduce Sensitivity	Press this key to reduce the amount of signal from the sonde.
2.	On/Off Control	Long press to switch on/off. Short press to change speaker volume.
3.	Increase Sensitivity	Press this key to increase the amount of signal from the sonde.
4.	Depth Measurement or Frequency Selection	A short press will calculate the depth to a sonde. Press and hold to enter frequency select menu, short press to exit the menu.

Power Mode Operation

Switch on the receiver by pressing the **On/Off** pushbutton. Allow the unit a few seconds to switch on. The frequency selected is shown on the display. If this is not the desired locate frequency (i.e. 50 or 60 Hz) change as instructed below.

Changing the Locate Frequency

Press and hold the **depth measurement/frequency selection** pushbutton until the frequency menu is entered. The display will show the present frequency selected in large numbers in the center of the screen. Use the "+" or "-" pushbuttons to select the desired frequency. Press the **depth measurement/frequency selection** pushbutton to re-enter the locate screen.

Locating a Cable in the Power (50/60 Hz) Mode

Hold the locator vertically in the area that is required to be searched. Adjust the sensitivity of the locator by pressing the "+" or "-" pushbuttons to keep the signal on scale. Hold the locator in front of you in the orientation shown below.

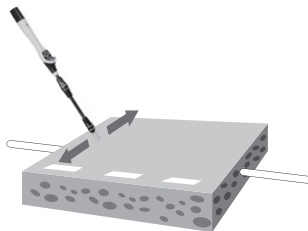

11 Locating Sondes and Pushrod

Sweep the locator left to right along the suspected route of the cable. As the locator approaches the cable the meter reading will increase. Pinpoint the position by detecting the largest signal.

To confirm the direction of the cable, rotate the locator until the largest signal is detected. The direction of the cable is then straight ahead, pointing forward, away from the display.

Continue to locate the cable along the route. Depth measurements are not possible in the power (50/60 Hz) mode, if pressed by accident it will show N/A.



WARNING

The power mode is used to detect signals radiating from cables or services that are carrying a 50 or 60 Hz load. It is possible for a cable to be live but not carry a load.

In this case there may not be a signal to be detected.

Similarly, if a cable is exactly balanced the resulting signal radiating from the cable may be zero and therefore not detectable.

Do not use the VM-540/VM-550/VM-560 to identify cables if they are live. Always dig with caution.

Sonde Locating with the VM-540

Power up the Sonde and securely attach it to a suitable duct rod for the application.

Insert the Sonde and position it to the pipe or duct leaving it still visible.

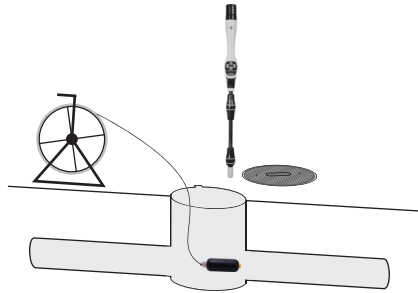

Hold the locator above the Sonde at ground level. Adjust the sensitivity of the locator by pressing the “+” or “-” pushbuttons to keep the signal on scale. Rotate the receiver until the maximum signal is detected.

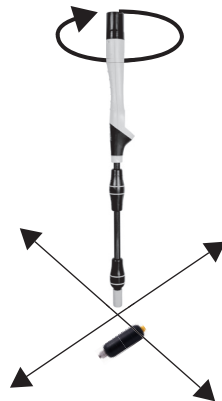

NOTE:

Moving the locator further left and right will result in detecting smaller “ghost” signals either side of the main one, this is normal. Always be sure to locate all three peaks when locating the position of the Sonde as the ghost signals are not directly over the Sonde. The largest one is the true position.

Moving back and forth across the Sonde will not detect ghost signals.

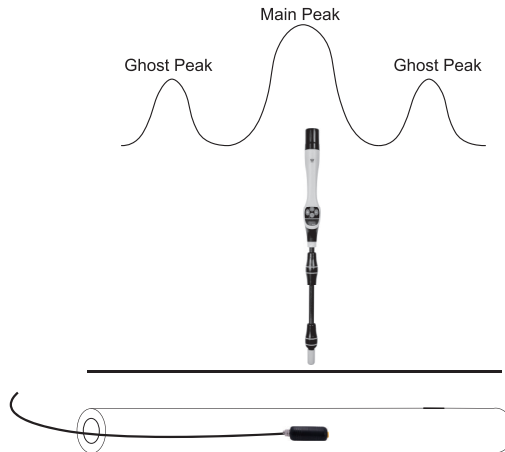

Now push the Sonde a few feet into the pipe. Stop and re-locate the Sonde. The direction of the Sonde can be confirmed by holding the locator vertically and rotating it on its axis until the largest signal is detected. The Sonde will then be pointing at right angles to the display.

Continue pushing a short distance and relocating as the Sonde is pushed into the pipe. Do not be tempted to push the rod too far into the pipe without locating the Sonde as this will make finding the Sonde more difficult.

Depth Measurement

To take a depth measurement first pinpoint the position and direction as previously described, pinpointing left/right, forward/back and also rotating on its axis. Hold the locator vertically over the position of maximum signal. Now press the “target” pushbutton. There will be a short delay before a depth estimate will be displayed.

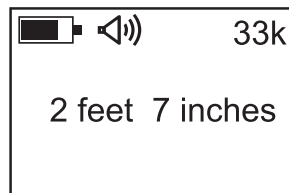

NOTE



The depth measurement is an approximation. Depth indications can be affected by field distortion caused by interference from in-band signals or metal structures such as rebar. An aid to determining if the depth is correct is to repeat a depth measurement with the locator a known distance (for example 1ft above the ground) and to note if the depth has increased by this amount. If it is different from what is expected treat the data as suspect.



IMPORTANT

Always “Call Before You Dig” and follow your own company’s safety practices.

Always follow local, state and national regulations.







12. Accessories

12.1. Skid Range



Model	Description & Diameter	Picture	Available for cameras
D25 Standard	Standard Skid, comes with the camera		D25-D and D25-M
D34 Standard	Standard Skid, comes with the camera		D34-C and D34-M
D46-CP Standard	Standard Skid, comes with the camera		D46-CP
D34 2.25" (58mm)	2.25" (58mm) Guide Skid		D34-C and D34-M
D34 3" (75mm)	3" (75mm) Guide Skid		D34-C and D34-M
D46-CP 3" (75mm)	3" (75mm) Guide Skid		D46-CP
D34 4" (101mm)	4" (101mm) Guide Skid		D34-C and D34-M
D46-CP 4" (101mm)	4" (101mm) Guide Skid		D46-CP
D46-CP 5" (127mm)	5" (127mm) Guide Skid		D46-CP
D34 Series D46 Series	Type "B" Adjustable Roller Skid		D34 and D46 Series
For Type-B Adjustable Skid	Light Kit for Type-B Adjustable Roller Skid		Fits Type-B Skid
<p>Contact a local Vivax-Metrotech distributor or local office for ordering information, applications, compatibility and pricing.</p>			

Aftermarket skids that fit the vCam series cameras may be available. Check with your local distributor for information.

12.2. Accessories





Description	Picture
<p>Extended Interconnect Cable, 26 feet - Extended 26 foot interconnect cable to allow more separation between the control module and reel.</p>	
<p>Insertion Sleeve Use the insert sleeve to help prevent scraping of the pushrod at the access point.</p>	
<p>Drip Bag, for Type-M2 Mini Reel Use drip bags when working indoors to help prevent water and debris from falling off the pushrod onto a floor or carpet.</p>	
<p>Drip Bag, for Type-CP Standard Reel Use drip bags when working indoors to help prevent water and debris from falling off the pushrod onto a floor or carpet.</p>	
<p>Rotate and Tilt Table A table that mounts between the Type-CP reel and control module which allows rotating and tilting of the control module.</p>	
<p>Sun Shield The Sun Shield mounts to the face of the second generation (DRD) vCam-5 control modules to shield the screen from the sun. Available for vCam-5 control modules with serial numbers above 1090 1100 003.</p>	
<p>Type-C vCam-5 Mounting Handle Assembly Replacing the original handle of the older Type-C reel with this version allows the newer vCam-5 control module to mount atop the older Type-C reel.</p>	 <p>(control module and reel not included)</p>
<p>Contact a local Vivax-Metrotech distributor or local office for ordering information, applications, compatibility and pricing.</p>	

12.3. Camera and Sonde Locators

Description	Picture
<p>VM-540 Sonde Locator The VM-540 locates Sondes and camera terminations with frequencies of 512Hz, 640Hz, 8.192 kHz, 9.82 kHz, and 33 kHz. This locator also has a passive power mode to search for live buried power, CATV and telephone cables or metallic pipes which may be radiating the 60Hz signal.</p>	
<p>vLocCam2 Sonde Locator The vLocCam2 locates Sondes and camera terminations with frequencies of 33 kHz, 512Hz or 640Hz. This locator also has a passive power mode to search for live buried power, CATV and telephone cables or metallic pipes which may be radiating the 50 or 60Hz signal.</p>	
<p>Contact a local Vivax-Metrotech distributor or local office for ordering information, applications, compatibility and pricing.</p>	

12.4. Sondes

Sondes are small battery powered transmitters that emit a frequency which can be located on the surface with a locator. The locator can pinpoint the sonde and calculate its depth. Sondes are available in different sizes, frequencies and depth ratings. Sondes are commonly used in non-metallic pipes and ducts where the conventional utility locator cannot locate it without a tracer wire or tape to assist it.

Picture	Model
	<p>D18 Series Sonde</p> <ul style="list-style-type: none"> • Dimensions: 0.75in (18mm) x 3.1in (80mm) long • Frequency: 33 kHz • Depth range: 15ft (4.5m). • Power: 2 x button cell batteries
	<p>D22 Sonde</p> <ul style="list-style-type: none"> • Dimensions: 0.875in (22mm) x 4.5in (114.3mm) long, • Frequency: 9.82 kHz or 83 kHz • Depth range: 8ft (2.44m) • Power: 4 x SR43W button cell batteries
	<p>D38 Series</p> <ul style="list-style-type: none"> • Dimensions: 1.5in (38mm) x 4.1in (105mm) long, • Frequency: 9.82 kHz, 33 kHz or 83 kHz • Depth range: 16.3ft (5m). • Power: 1 x AA Alkaline battery
	<p>D64 Series Sonde</p> <ul style="list-style-type: none"> • Dimensions: 2.5in (64mm) x 7.3in (186mm) long, • Frequency: 9.82 kHz, 33 kHz or 83 kHz • Depth range: 26ft (8m). • Power: 1 x AA Alkaline battery
	<p>D23 Series Sonde</p> <ul style="list-style-type: none"> • Dimensions: 1in (23mm) x 18in (456mm) long, • Frequency: 512Hz or 640Hz • Depth range: 20ft (6m). • Power: 1 x AA Alkaline battery
<p>Contact a local Vivax-Metrotech distributor or local office for ordering information, applications, compatibility and pricing.</p>	

13. Troubleshooting

<p>PROBLEM: No power, unit will not turn on:</p>
<p>CHECK:</p> <ol style="list-style-type: none"> 1. Check to see that the fuse is installed, blown or damaged in any way. If the fuse is not installed then the unit will not charge your battery. 2. Try using mains current and not battery to turn on the unit. If the unit does power on with mains current then your battery is not charged and that may be the reason it will not power on. 3. While the unit is charging see if the battery icon on the front panel is glowing red, or if turned on that you see a lightning bolt inside the battery icon on the bottom right corner of the LCD. <p>Note: On serial numbers below 1090 1100 00001 the charging indicator will glow red while charging and go blank when fully charged. On serial numbers above 1090 1100 00001 the charging indicator will glow red while charging and turn green when fully charged.</p>
<p>PROBLEM: No picture with no grey status bar:</p>
<p>CHECK:</p> <ol style="list-style-type: none"> 1. Check that both ends of the interconnect cable are plugged in. 2. If the camera has lighting then remove it and plug into the camera test port. 3. Check both ends of the coiled cable in the spring. With the camera connected and powered on move the cable at the ends to see if the loss of video is intermittent.
<p>PROBLEM: Black screen, no picture with grey status bar:</p>
<p>CHECK:</p> <ol style="list-style-type: none"> 1. Perform a visual check looking for possible point's water entry. Check the camera head looking for cracks in the glass lens or plastic LED cover. 2. Plug camera head into the camera test port looking for video and lighting. 3. Inspect the coiled cable for cuts or chafing. Flex both end of the coiled cable looking for an intermittent connection under the cable jacket. 4. Inspect the interconnect cable looking for cuts or chafing. Flex both ends of the cable looking for an intermittent connection under the cable jacketing.
<p>PROBLEM: Not recording:</p>
<p>CHECK:</p> <ol style="list-style-type: none"> 1. Check the battery level. When the battery is low the unit may not have enough power to record. 2. Check available disk space on the HDD, USB or SD card. 3. Check your default storage setting.
<p>PROBLEM: Sonde not working:</p>
<p>CHECK:</p> <ol style="list-style-type: none"> 1. Check the battery level. When the battery is low the sonde may not operate. 2. Check that the sonde frequency in the control module matches that of the sonde locator.

<p>PROBLEM: Distance counter not accurate:</p>
<p>CHECK: In the menu settings for reels check: 1. Meters or Feet 2. Type of reel selected and footage of reel Also check that the friction brake is not slowing down the cage so much that it jerks in and out.</p>
<p>PROBLEM: Distance counter no counting:</p>
<p>CHECK: Check the condition of the Interconnect Cable between the control module and reel. With the unit powered on and interconnect cable attached between the control module and reel twist the interconnect cable wire close to the connectors while watching the distance counter on the display. Try and switch the interconnect cable with another working unit.</p>
<p>PROBLEM: Interference or noise on LCD:</p>
<p>CHECK: The Sonde in some circumstances can cause interference on the video being viewed or recorded. It is recommended that the Sonde is turned off unless it is actually being used for location. This also saves power.</p>
<p>PROBLEM: Control Module keeps rebooting because of "Control Module settings have changed" message:</p>
<p>CHECK: Check for loose connections to or damage to the termination coiled cable, interconnect cable or damage to the reel.</p>
<p>PROBLEM: SD or USB device not recognized:</p>
<p>CHECK: Make sure the media device is working and not corrupt. Try formatting the device in the control module. Read the section in this manual "File Format of SD Cards and USB Drives"</p>
<p>Problem: No audio being heard on recorded video:</p>
<p>CHECK:</p> <ol style="list-style-type: none"> 1. Check that volume is turned up during playback. Use key function Ctrl - to lower volume and Ctrl + to raise the volume. 2. Assure that the red microphone icon was showing on the status bar and hat the microphone button was illuminated during the audio recording. 3. Assure that the audio comments were directed towards the internal microphone between one and three feet from the internal microphone. 4. Try using an external microphone

<p>Problem: Dark or hard to view display:</p>
<p>CHECK: Press the "F9 Display" key and check the display settings. Turn the camera LED lights up.</p>
<p>Problem: Cannot connect by WiFi or Ethernet.</p>
<p>CHECK:</p> <ol style="list-style-type: none"> 1. Check that the correct password(s) are being used. WiFi connect = 12345678 Ethernet connect = 12345678 App setup password = 123456 2. Check the App setup credentials are correct (see WiFi section of this manual) 3. Check that the internet explorer browser setup is correct. 4. If using the app check that you connect the phone/tablet to the control module first and then launch the app. <p>See WiFi section of this manual</p>
<p>Problem: Error messages for USB and SD cards, not enough free space or not found.</p>
<ol style="list-style-type: none"> 1) Check that the USB device is a minimum of 8GB in size and not bigger than 128GB in size. 2) Check that the USB device was formatted in FAT32 or NTSC file format.

