



SERVICE CENTER, SALES AND TECHNICAL SUPPORT INFORMATION

Corporate Headquarters
3251 Olcott Street
Santa Clara, CA 95054
800-446-3392
408-734-1400 Direct
408-734-1415 Fax
www.metrotech.com
sales@metrotech.com

Metrotech Eastern U.S. Service Center
5211 Linbar Drive, Suite 503
Nashville, TN 37211
800-624-6210
615-366-7323 Direct
615-360-9855 Fax
nashville@metrotech.com

Metrotech European Service Center
Seba KMT
Dr. Herbert Iann St. 6
96148 Baunach, Germany
+49 9 544 680
+49 9 544 2273 Fax
service@sebakmt.com



ISO 9001 CERTIFIED

Metrotech has received ISO 9001 Quality Management System Certification.

Metrotech adheres to the quality standard guidelines of ISO 9001 and ensures quality in its design/development, production, installation, and servicing disciplines.

© Metrotech Corporation 2008

Metrotech Corporation
3251 Olcott Street
Santa Clara, CA 95054
USA

Tel: 1.800.446.3392; 1.408.734.1400

Fax: 1.408.734.1415

E-mail: sales@metrotech.com

Internet: www.metrotech.com

Table of Contents

1.	Introduction	5
2.	810 Equipment	7
	2.1 Standard Equipment.....	7
	2.2 Optional Equipment.....	7
	2.3 Technical Specifications.....	8
	2.4 810 Transmitter: Controls & Indicators.....	9
	2.5 810 Receiver: Controls and Indicators.....	10
3.	Checkout Procedures	12
4.	Operation	15
	4.1 Transmitter – Direct Connection.....	15
	4.2 Transmitter – Inductive Coupling with the Metroclamp.....	16
	4.3 Transmitter – Inductive Method.....	17
	4.4 Using the Receiver.....	19
	4.5 Determining the Depth of a Conductor.....	20
	4.6 Conductor Identification Using a Second Metroclamp.....	21
	4.7 Marking the Conductor.....	21
5.	Ground Survey Procedure	22
	5.1 Applications.....	22
	5.2 Locating Conductors.....	22
	5.3 Subdividing Large Search Areas.....	22
6.	Tracing Techniques and Helpful Information	23
	6.1 Soil Conditions.....	23
	6.2 Adjacent Conductors.....	23
	6.3 Metroclamp: Ground Requirements.....	23
	6.4 Grounding: Safety.....	23
	6.5 Distribution Systems.....	23
	6.6 Deep Conductor.....	23
	6.7 What is the field Strength of the Signal?.....	23
	6.8 “Ghost” Conductor Due to Adjacent Conductor.....	23
	6.9 Completing the Circuit Path.....	24
	6.10 Common Bond Conductors.....	24
	6.11 Congested Areas.....	24
	6.12 Locating a Service Lateral.....	25
	6.13 Valves, Manhole Covers, Tees and Risers.....	25
7.	Maintenance	26
	7.1 810 Receiver Calibration.....	26
	7.2 Replacing the 810 Receiver Batteries.....	26
	7.3 Replacing the 810 Transmitter Batteries.....	26
	7.4 Metrotech Service Center.....	27
8.	Copyright	28
9.	Warranty	28

List of Illustrations

Figure	Page
2-1 810 Line Tracer: Standard and Optional Equipment.....	6
2-2 810 Transmitters: Controls and Indicators.....	9
2-3 810 Receiver: Controls and Indicators.....	10
3-1 Position of Receiver for Checkout Procedure, Step 6.....	11
3-2 Checkout of Receiver Directional Meter.....	12
3-3 Configuration for Testing the Conductive Attachment.....	13
3-4 Configuration for Testing the Metroclamp.....	14
4-1 Direct Connection.....	15
4-2 Inductive Coupling with the Metroclamp.....	16
4-3 Signal Field Generated by Transmitter When in Inductive Use	17
4-4 Position of Transmitter for Inductor Use.....	17
4-5 Position of Receiver.....	18
4-6 810 Receiver Guidance System.....	18
4-7 Determining the Depth of a Conductor.....	20
4-8 Position of Metroclamps When Using Two.....	21
5-1 Locating Conductors: Parallel Pattern.....	22
6-1 Ground on Either Side of Trace Area.....	24
6-2 Position of Transmitter for Minimum Interference.....	25
6-3 Locating Service Laterals.....	25
7-1 Replacing the 810 Transmitter Batteries.....	26

1 INTRODUCTION

The Metrotech Model 810 Radio Frequency Line Tracer is an excellent instrument for tracing water and gas distribution lines, cables, inductive locating, and blind searching. The high frequency signal is able to jump insulators and rubber gaskets often found in water and gas distribution systems. Since the radio frequency travels easily through the soil, the 810 is an ideal instrument for inductive locating. The floodlight Quality of the RF signal will induce signal onto conductors 8-10 ft. on either side of the Transmitter making it an excellent instrument for blind searches.

The 810 Transmitter generates a signal which is applied onto the pipe or cable (conductor). The signal travels along the conductor, becoming weaker as it gets farther away from the Transmitter. The distance that the signal travels before it becomes too weak to be detected depends on the method of connection, the type of conductor surrounding soil, and depth of the conductor.

When positioned over the conductor, the Receiver will detect the signal from the conductor. The Receiver's Left/Right Guidance System, field strength display, and audio tone aid you in tracing. To display the depth of the conductor, you simply push a button.

The Model 810's automatic impedance matching compensates for differences in soil conditions, conductor size and material.

As with all electromagnetic locating systems, this nit is designed to locate metallic conductors only. The word "conductor, pipe, or cable" refers to a metallic conductor throughout this manual.



Figure 2-1: 810 Line Tracer: Standard and Optional Equipment

2. 810 EQUIPMENT

The Metrotech 810 Line Tracer consists of standard and optional equipment. All equipment is shown in Figure 2-1.

2.1 Standard Equipment

<u>Part Number</u>	<u>Description</u>	<u>Remarks</u>
810	Transmitter	.25 watt
810 or 800C025 (metric)	Receiver	
800B004	Conductive Attachment Assembly	Direct Connect Cable Ground Spike, and Ground Plate
400C079	Carrying Case	
600A001-E	Operation Manual	

Features of the Model 810 Transmitter and Receiver are discussed in detail in sections 2.4 and 2.5.

2.2 Optional Equipment

<u>Part Number</u>	<u>Description</u>	<u>Remarks</u>
4820 (4")	Metroclamps*	Optimally tuned to the 810
4890 (8")	Metroclamps*	Compatible with other
4490 (4")	Metroclamps*	Metrotech locators
4290 (2")	Metroclamps*	
	*jumper cable included with all clamps	
183045	Headphones	For use when locate site is too noisy for audio tone
SON830	Sonde	For tracing non-metallic Pipe for conduit
600A071	VHS Video Tape	SECAM Training Tape
600A072	VHS Video Tape	PAL Training Tape
600A073	VHS Video Tape	NTSC Training Tape

2.3 Technical Specifications

810 Transmitter

Output Power:	250mW
Output Frequency:	83.0775kHz \pm .002% Crystal controlled for Interference resistance
Battery Type:	Six NEDA 13F "D" Cells, Alkaline
Battery Life:	150 hrs. average
Battery Check:	Power on, push Power Test button
Operation Temperature:	0 to 110° F (-18 to 43° C)
Weight:	3.9 lbs. (1.8 kg)
Dimensions:	8"L x 3.25"W x 6.5"H (20.3 x 10.5 x 17.2 cm)

810 Receiver

Trace Accuracy:	\pm 1 inch from 0 to 3 ft (91 \pm 3% over 3 ft (91cm) in depth
Depth Readout Accuracy:	\pm 10% under normal conditions
Depth Readout Range:	To 13 ft. (400 cm)
Sensitivity Control:	Automatic, no adjustments Necessary
Battery Type:	4NEDA 1604A Alkaline (9V), IEC 6LR61 (Int'l Std.), or JIS 6AM6 (Jpn Std)
Battery Life:	145 hrs. average
Battery Check:	Turn Mode Switch to Batt Test
Operation Temperature:	0 to 110°F (-18 to 43°C)
Weight:	4.1 lbs. (1.9 kg)
Dimensions (extended length):	32.5"L x 7.25"W x 12.25"H (82.6 x 18.4 x 31.1 cm)

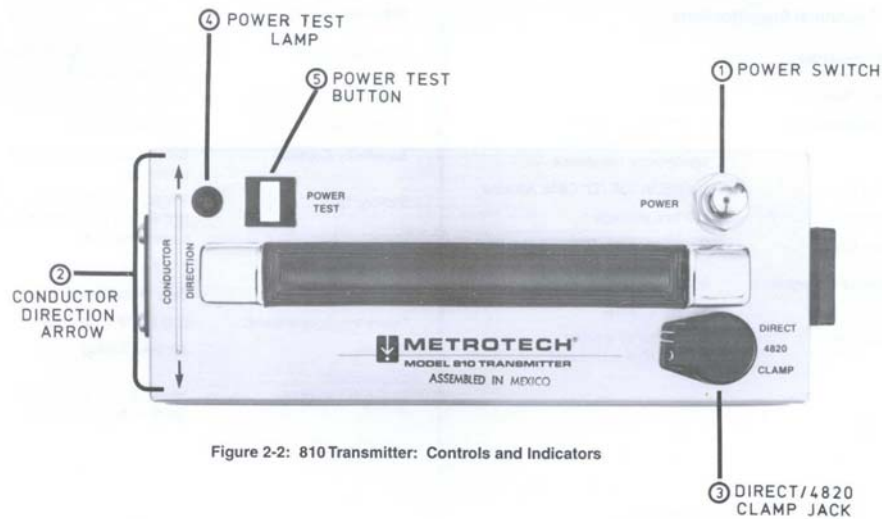

Figure 2-2: 810 Transmitter: Controls and Indicators

Figure 2-2: 810 Transmitter: Controls and Indicators

2.4 810 Transmitter: Controls and Indicators

Figure 2-2 Designation

- 1 **POWER ON/OFF SWITCH**
Pull this switch to turn the Transmitter on.
- 2 **DIRECT/4820 CLAMP Output Jack**
Connection point for the Direct Connect cable
Or any Metroclamp
- 3 **CONDUCTOR DIRECTION Arrow**
Orients the Transmitter when used in Inductive Mode.
- 4 **POWER TEST Lamp**
If there is adequate battery power for operation, this lamp will light up when you push the POWER TEST button
- 5 **POWER TEST Button**
Push this button to determine if there is adequate battery available for operation.

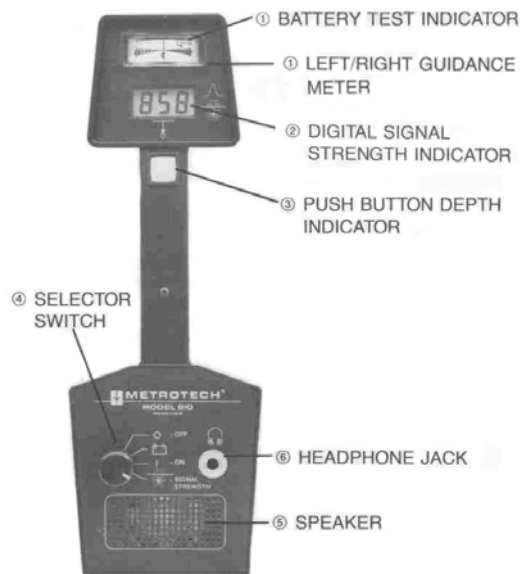







Figure 2-3: 810 Receiver: Controls and Indicators

2.5 810 Receiver: Controls and Indicators

Figure2-3 Designation

- 1 **LEFT/RIGHT GUIDANCE METER**
The centerline needle guides you toward the conductor. If the needle is in the right-hand (solid) portion of the Meter, move the Receiver to the right. If the needle is in the left-hand (broken) portion of the meter, move the Receiver to the left.
- BATTERY STATUS**
When the MODE SWITCH is turned to the Battery Test position, the meter needle should move to the right of the battery test arrow.
- 2 **DIGITAL SIGNAL STRENGTH**
The signal strength is indicated on the LCD display when the MODE SWITCH is in the line-tracing mode (third position) or field strength only mode (fourth position).
- 3 **DEPTH PUSH BUTTON**
In order to get a depth reading, the MODE SWITCH Must be in the third position. Press and release this Button to get a conductor depth of the conductor in inches (or centimeters)

- 4 **MODE SWITCH**
This switch has four possible settings:
-  **Power Off**
 -  **Battery Test**
In this position, needle should be to the right of the battery line.
 -  **Line Tracing Mode**
Use this position for normal operation.
 -  **Field Strength Only**
This position eliminates the tone and Left/Right Guidance System and the depth measurement capability. The signal strength for pinpointing the conductor continues to be operational.
- 5  **HEADPHONE JACK**
For use in noisy environments.
- 6 **SPEAKER**
The speaker in the Receiver emits a tone, which corresponds to the position of the needle on the Left/Right Guidance meter. A continuous tone (solid arrow) indicates the conductor is to the right. A broken tone (broken arrow) indicates the conductor is to the left.

Back of Receiver

- 7 **BATTERY ACCESS (Thumbscrew)**
Turn the thumbscrew to gain access to the batteries.
- 8 **AUX INPUT (auxiliary input)**
Point of connection for the 4820 Metroclamp.

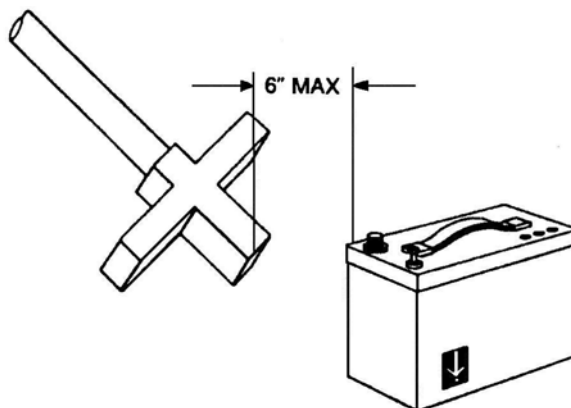

Figure 3-1: Position of the Receiver for Checkout Procedure, Step 6

3 CHECKOUT PROCEDURE

To insure proper operation of the 810 Line Tracer, use the checkout procedure below at the following times:

- Upon receiving the equipment
- Before each job, preferably before you leave for the site
- If problems arise during a locate

Checkout Steps:

- 1 Turn the Transmitter ON/OFF switch to the "ON" position.
- 2 Within seconds the lamp next to the POWER SWITCH on the Transmitter should flash, indicating that the 810 Transmitter is ready to operate.
- 3 Fully extend the Receiver antenna by loosening the nut on the stem assembly and extending the stem as far as possible.
- 4 Set the Receiver MODE SWITCH to battery test (second position).

The needle on the Left/Right Guidance meter should move to the right of the line labeled BATT TEST. The farther the needle is to the right of this line, the greater the charge in the batteries. If the needle is to the left of the line, the Receiver batteries should be replaced.
- 5 Move the Receiver MODE SWITCH to the AUX position (fourth position).
- 6 Position the Receiver as shown in Figure 3-1. The digital signal strength indicator should display 950 or above.

Note the field strength figure, you will be using it for comparison in the next steps of the procedure.
- 7 With the Receiver MODE SWITCH in the line-tracing mode (third position), move the Receiver back from the Transmitter 2-5 feet. Point the Receiver at the Transmitter as in Figure 3-1, the Left/Right Guidance needle will be centered on the meter and the tone will be silent.
- 8 Point the Receiver to the left and right of the Transmitter centerline. The needle should follow the change in direction (solid arrow and continuous tone when you move right, broken arrow and broken tone when you move left). See Figure 3-2.

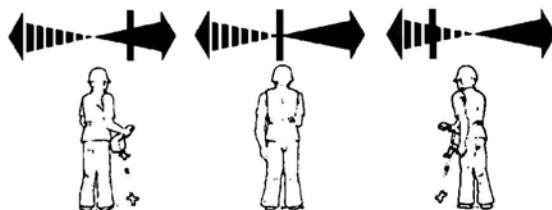

Figure 3-2: Checkout of Receiver Directional Meter

- 9 Center the needle on the meter as in Step 7.
- 10 When the needle is centered, press and release the DEPTH button. A depth reading should appear.
- 11 Turn the Transmitter OFF by pushing the POWER SWITCH down.

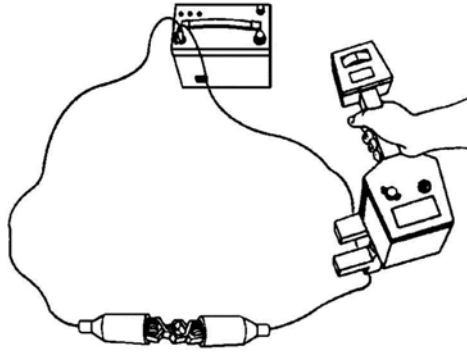

Figure 3-3: Configuration for Testing the Conductive Attachment

To test the conductive attachment for loose or broken wires:

- 12 Connect the BLACK and RED ends of the Conductive Attachment together. Lay the connected wires out on the floor in a circular configuration (see Figure3-3). Plug the Conductive Attachment into the DIRECT/4820 CLAMP jack of the Transmitter.
- 13 Turn the Transmitter on by pulling the POWER SWITCH up.
- 14 Place the Receiver tip directly on one of the conductive wires.
- 15 Turn the MODE SWITCH on the Receiver to the fourth position (field strength only). The field strength should be the same or very close to the reading in test procedures 5 and 6 above. The reading should be constant and not fluctuate.
- 16 While watching the field strength readout, wiggle each connection point on the Conductive Attachment at the DIRECT/4820 CLAMP jack and at the clamp end of each of the Conductive Attachment wires (red and black). The field strength should not change. Any fluctuation in the reading indicates a loose or broken wire within the conductive attachment.
- 17 Repeat step 16 on the other conductive wire.
- 18 Turn the Transmitter OFF.

To test your Metroclamp for loose or broken wires:

- 19 Keeping the Conductive Attachment in the loop configuration shown in Figure 3-4, unplug the attachment from the Transmitter and plug it into the Metroclamp jack on the back of the 810 Receiver. Position the Receiver on the floor or ground so that you can read the field strength readout.

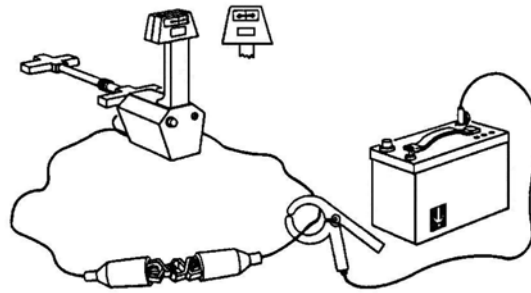

Figure 3-4: Configuration for Testing the Metroclamp

- 20 Plug your Metroclamp into the DIRECT/4820 CLAMP jack of the 810 Transmitter. Then position the jaws of the Metroclamp around one of the wires of the Conductive Attachment (still in the loop configuration) and lay it on the floor or ground.
- 21 Turn the Transmitter back ON.
- 22 Note the field strength shown on the Receiver; it should be close to that of step 15 above.
- 23 While watching the field strength readout, gently wiggle the wires at each of the connection points. Any fluctuation in the field strength readout indicates a loose or broken wire within the Metroclamp.
- 24 Turn both the Transmitter and Receiver off and unplug both the Metroclamp and the Conductive Attachment to avoid excessive battery loss.

See Section 7 for information on testing and replacing batteries.

If there are any questions about this procedure or the use of the instrument, contact the Metrotech Service Department: 1-800-638-7682

4 OPERATION

Follow the checkout procedure described in Section 3 before operating the equipment.

To operate the 810 Line Tracer, use the 810 Transmitter to apply a signal to the conductor, and use the 810 Receiver to trace the signal.

DANGER – ELECTRICAL SHOCK

When making a direct connection to a live power cable, always be sure the power to the cable is turned OFF by using a voltmeter to check for active electrical power. (Live secondary power can be located safely using an Inductive clamp.

WARNING – ELECTRICAL SHOCK

The 810 Transmitter generates up to 75 volts AC p-p. To avoid electrical shock, handle the conductive leads one at a time when the Transmitter is ON.

CAUTION – INACCURATE INFORMATION

Do not operate the Transmitter while it is resting on or near a metal surface or large metal object. Incorrect test readings and damage to the Transmitter may result.

There are three different methods of applying the signal to the conductor with one of the Transmitters – Direct Connection, Inductive Coupling, and Inductive. A description of each method and use instructions follow below:

4.1 Transmitter – Direct Connection

This is the preferred mode of operation because the Transmitter is connected directly to a metallic part of the conductor (hydrant, meter, riser, valve, sheath, tracer wire) allowing a strong maximum signal to reach the conductor. In this operating mode the Receiver can be closer to the Transmitter. Adjacent buried conductor interference is reduced.

- 1 With the Transmitter OFF, plug the Direct Connect Cable into the jack labeled DIRECT/4820 CLAMP on the 810 Transmitter.
- 2 Attach the RED lead of the Direct Connect Cable to an electrical clean metallic part of the targeted conductor.
- 3 Move the Transmitter away from the conductor in a right angle direction as shown in Figure 4-1 on the next page.

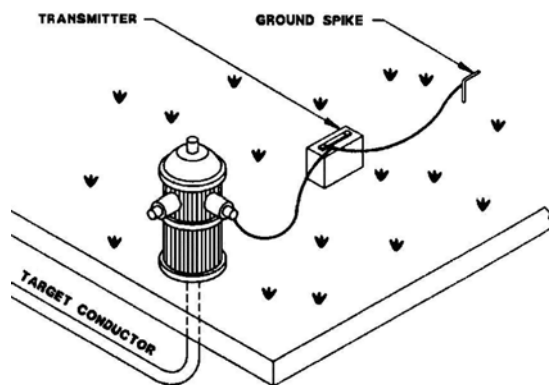

Figure 4-1: Direct Connection

- 4 Extend the BLACK lead of the Direct Connect Cable as far as possible from the Transmitter, maintaining the right angle orientation. At this point, drive the ground spike into the ground as far as possible, and attach the BLACK lead to it. Use the ground plate only when the ground surface is too hard to drive a spike into it. Place the plate on the ground (at right angles to the conductor) and attach the BLACK lead. To improve the conductivity of the plate, put water and/or a weight on it.

- 5 Pull the POWER SWITCH up to turn the Transmitter ON.
- 6 Trace the signal with the Receiver; see Section 4.4 for Receiver Operating Instructions.

4.2 Transmitter – Inductive Coupling with a Metroclamp

Use this method if Direct Connection is not possible, but you can position a Metroclamp around the conductor you want to trace. The Inductive Coupling method uses a Metroclamp to induce a signal onto the conductor when direct metallic contact is not possible. The clamp is placed around the target conductor. The Transmitter then induces a signal through the clamp.

When using the Metroclamp, the conductor must be well grounded at both ends. When tracing lines that have insulators, the insulators should be bypassed, using the supplied jumper cables. Bonding and grounding at termination is often “standard practice” in industries that use cable, but do not assume this to be the case.

- 1 With the Transmitter OFF, plug the Metroclamp cable into the DIRECT/4820 Clamp jack.
- 2 Place the Metroclamp around the conductor, below the electrical ground. (See Figure 4-2). Make sure that the clamp jaws are completely closed.
- 3 Follow steps 3-6 Direct Connection.
- 4 Trace the signal with the Receiver; see Section 4.4 for Receiver Operating Instructions.

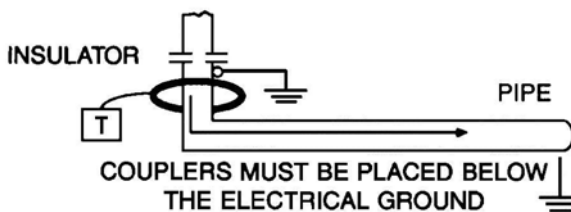

Figure 4-2: Inductive Coupling with the Metroclamp

4.3 Transmitter – Inductive Method

If you cannot make a direct Connection onto the conductor, or use the Metroclamp, use the internal antenna of the Transmitter to induce signal onto the conductor. See Figure 4-3.

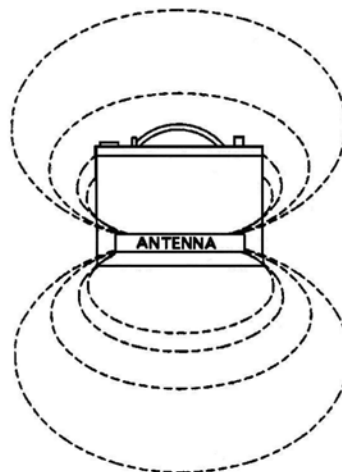

Figure 4-3: Signal Field Generated by Transmitter When in Inductive Use

This is the least preferred method of inducing signal onto a conductor because the signal is broadcast through the soil and the air and can be picked up by other conductors in the area. In this mode the signal radiates from an antenna inside the bottom of the Transmitter housing and couples to the conductor by electromagnetic induction.

- 1 Position the Transmitter over the target conductor at a place that is at least 30ft. away from where you will be searching with the Receiver. (If the Transmitter is very close to the Receiver, more signals may reach the Receiver by air coupling than by coupling through the conductor). Align the CONDUCTOR DIRECTION arrow with the conductor. (See Figure 4-4).
- 2 Pull the POWER SWITCH "ON".
- 3 Trace the signal with the Receiver as described in the following section. To determine if you are air coupling, raise the Receiver above the target conductor. If the signal does not decrease, you are air coupling. Move further away from the Transmitter.

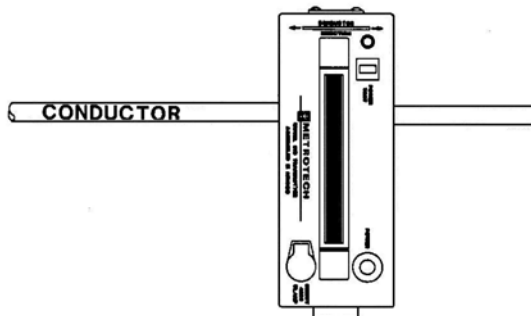

Figure 4-4: Position of Transmitter for Inductive Use.



Figure 4-5: Position of Receiver for Tracing

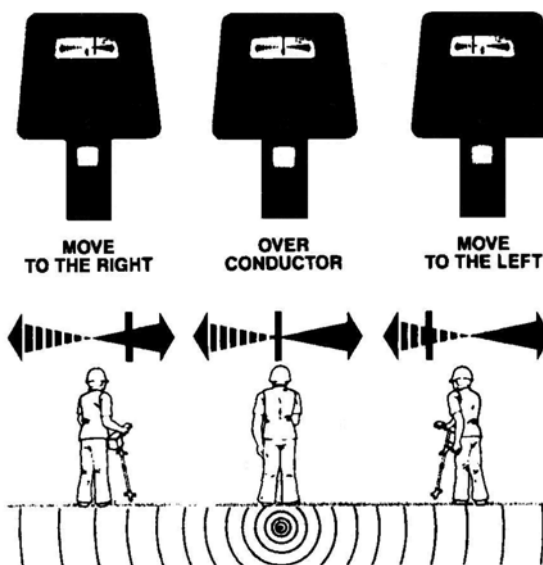

Figure 4-6: 810 Receiver Guidance System

4.4 Using the Receiver

The following describes using the Receiver with any of the three methods of applying Transmitter signal.

- 1 Loosen the nut on the Receiver stem assembly and extend the stem as far as possible. Tighten the nut to secure the stem.
- 2 Turn the Receiver MODE SWITCH to the third position.
- 3 Go to the search area. Hold the Receiver in a comfortable position in front of you and sweep the area, moving the Receiver from side to side.
- 4 The Left/Right Guidance, signal strength, and audio tone will guide you toward the conductor. The needle on the Left/Right Guidance meter will move to the right and the tone will be steady if the conductor is to your right. The needle will move to the left and the tone will pulse if the conductor is to your left. The signal (or field) strength on the digital display (LCD) will rise as you approach the conductor.

As you close in on the location of the conductor, the meter needle will move toward the center, the signal will peak and the tone will be silent. See Figure 4-6.
- 5 To determine the direction of the conductor, touch the Receiver tip to the ground over the conductor and rotate it on its vertical axis. The highest signal strength reading indicates the direction of the conductor.

Continue to trace the conductor in the direction indicated by the Receiver. If the signal strength drops abruptly, the conductor may have changed direction or stopped.
- 6 To verify the conductor's location, press the depth button. A stable depth reading should appear on the LCD. If the display is blank, you are no longer over the conductor. If irrational or blinking numbers appear on the LCD, you may be over an interfering conductor, or a conductor that is beyond the depth range of the instrument. (13ft.)
- 7 When you have pinpointed the conductor's location, mark it as required. See Section 4.7 for APWA color markings.
- 8 When you have finished the locate, turn the Receiver OFF, loosen the nut and retract the Receiver stem.
- 9 Turn the Transmitter OFF and put all components back into the carrying case.

4.5 Determining the Depth of a Conductor

To determine the depth of a conductor accurately, the 810 field strength must be greater than 500. Keep in mind that depth measurements are affected by soil condition, overhead lines, and adjacent conductors. In congested areas it is preferable to use Direct Connect when determining depth.

- 1 First determine the location of the conductor using any of the methods described above (Direct Connection, Inductive Coupling, or Inductive Method).
- 2 Make sure the Receiver antenna is fully extended, otherwise, the depth reading will be incorrect.
- 3 Facing in the direction of the conductor, touch the antenna tip to the ground directly above the conductor, with the Receiver at right angles to the ground. (See Figure 4-7).
- 4 Press and release the DEPTH BUTTON on the handle of the Receiver. Within seconds, the digital display will show the depth of the conductor in inches or centimeters, depending on the instrument version.



Figure 4-7: Determining the Depth of a Conductor

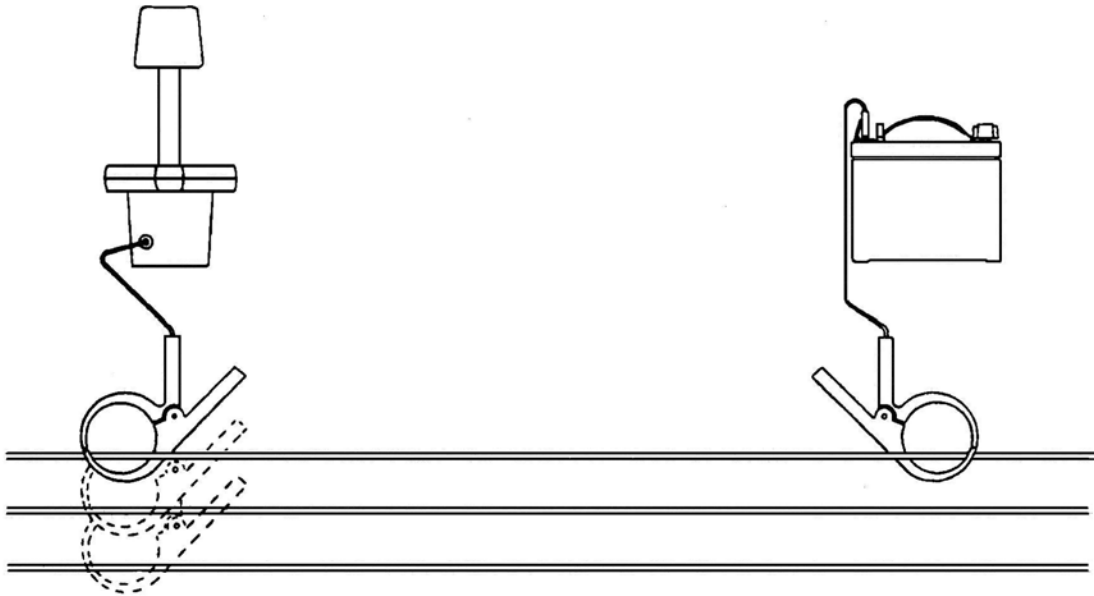

Figure 4-8: Position of Metroclamps When Using Two

4.6 Conductor Identification using a Second Metroclamp

When exposed, multiple conductors are present, for example in conduits or ducts, use the method described below to identify a specific conductor.

- 1 Plug a second Metroclamp cable into the jack marked AUX INPUT on the back of the Receiver.
- 2 Set the Receiver MODE SWITCH to the fourth position – Field Strength only. Turn the Transmitter ON.
- 3 Place the Metroclamp around each conductor in succession, making sure that the jaws are fully closed. The conductor with the highest field strength reading is the target conductor. (Figure 4-7)

Note: The method will work only if there is no cross bonding on the length of the conductor between the conductor and the Receiver.

4.7 Marking the Conductor

The following color markings have been established by the American Public Works Association (APWA):

<u>Conductor</u>	<u>Color</u>
electric power lines, cables, or conduits	red
communication lines, cables, or conduits	orange
gas, oil, petroleum, or other gaseous materials	yellow
storm and sanitary sewers; drain lines	green
water, irrigation, or slurry lines	blue

Note: If you have any questions regarding marking requirements or procedures, please call your local One Call Center.

5 GROUND SURVEY PROCEDURE

5.1 Applications

Regulations at construction sites often require a ground survey before any excavation is undertaken in the presence of underground utilities such as power, telephone, CATV, gas and water lines.

5.2 Locating Conductors

When undertaking a ground survey, use one of the three modes of operation (Direct Connect most accurate) to locate the known (if any) utilities and mark their location on the ground. Then, using the Inductive mode (Operation Section 4.3, Inductive Method), two operators – one carrying the Transmitter, the other operating the Receiver – move in parallel across and then down the survey area. (The operator with the Receiver must move sideways, facing the direction in which he is moving as shown in Figure 5-1). The LCD reading on the Receiver will indicate the presence of a conductor under the ground as the operator passes over it. Mark the location of each conductor along your survey path. After executing this procedure in both directions, go back and trace the path of each of the conductors you have marked.

5.3 Subdividing Large Search Areas

If you are working in a large search area, subdivide it into several smaller areas. Then sweep through each smaller area thoroughly before going on to the next one.

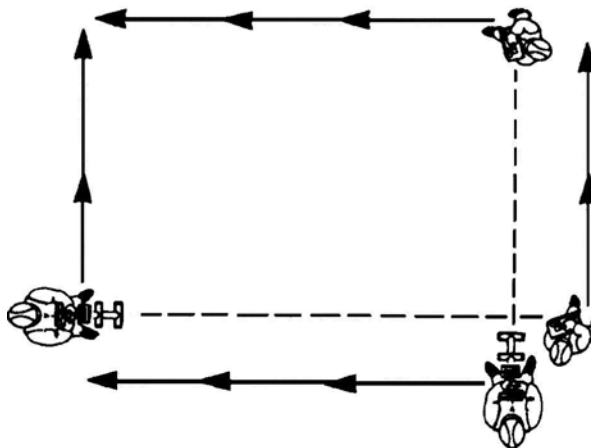

Figure 5-1: Locating Conductors: Parallel Pattern

6 TRACING TECHNIQUES AND HELPFUL INFORMATION

Many variables affect the process of locating a pipe or cable. The following information gives guidelines for various problem situations.

6.1 Soil Conditions

Generally, the effect of soil types on line tracing is as follows:

<u>Soil Type</u>	<u>Effect on Line Tracing</u>
moist, compact	ideal
dry, sandy, or rocky	little or no moisture content creates A poor tracing environment
alkaline, high iron content	poor tracing environment

6.2 Adjacent Conductors

If the field strength reading drops off more on one side of a conductor than it does on the other, the Receiver may be picking up interference from an adjacent or parallel conductor. Confirm the exact location of the adjacent conductors. Place your ground lead so that it does not cross over any adjacent conductors, but is as far away from your target conductor as possible, and is extended perpendicular to the direction in which you are tracing.

6.3 Metroclamp: Ground Requirements

If you are using the Metroclamp around a cable, both ends of the target conductor must be grounded to insure sufficient field strength. Power lines and telephone sheaths are assumed to be grounded.

If the conductor is a pipe which had an insulated joint, such as a gas pipe with a meter, use the jumper cable. Attach each end of the jumper cable on opposite sides of the insulator.

6.4 Grounding: Safety

If you use the Direct Connect method, be sure that there is no power flowing through the target conductor. If you use the Metroclamp on energized lines, follow established safety procedures.

6.5 Distribution Systems

To locate gas services on a gas distribution system, you must be sure that the service is grounded. This can be accomplished by temporarily connecting a jumper cable to a ground spike at the end of a service, where the pipe comes out of the earth.

6.6 Deep Conductor

Signals picked up by the Receiver from deep buried cables are weaker and not as directional distinct as those from cables closer to the surface. The meter reading will only change by small increments in relation to moving the Receiver antenna.

Using the Inductive (indirect) Method of coupling signal to the conductor may be difficult if the target conductor is buried three feet or more, or is set in recent backfill. For best results, use the Direct Connection method of coupling signal to the targeted conductor. (Section 4.1)

6.7 What is Field Strength of the Signal?

When the signal is applied to the conductor using any of the three methods described in Section 5, an electromagnetic field is created on the conductor. The Receiver measures the strength of this field, displaying it on the digital meter.

The field strength decreases as you move away from the target conductor and as you go farther away from the Transmitter. For optimum tracing accuracy, the field strength should be between 975 and 500.

Measurement accuracy is affected by the ratio of the conductor diameter compared to how deep the conductor is buried. For example, a conductor with a diameter of one foot should have two feet of top fill to endure an accurate measurement.

6.8 "Ghost" Conductor Due to Adjacent Conductor

If there is another conductor near the target conductor, it too may pick up the signal from the Transmitter. When this occurs, there will seem to be a trace – a "ghost" trace – between the two conductors.

A ghost trace can be detected by noting the following:

- 1 When the Left/Right Guidance needle changes direction and the tone changes from broken to solid or solid to broken and the Left/Right Guidance meter needle moves in the same direction as you are moving. (Normally, the Left/Right Guidance needle moves in the opposite direction.)
- 2 The field strength reading will drop as you move toward the “ghost” conductor. (Normally, field strength would increase.)
- 3 If you take a depth measurement over a “ghost” conductor, you will get a random or illogical reading, or no reading at all.

The Receiver reads a “ghost” conductor when each coil on each side of the cross section of the antenna receives the same amount of signal from two separate conductors.

The location of the “ghost” will vary, according to the soil conditions and the size, depth, and conductivity of any adjacent conductors.

To re-establish the correct trace, backtrack and search the area in a 180-degree arc.

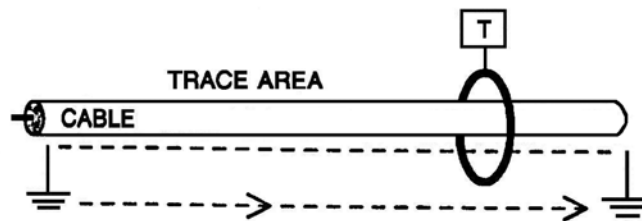

Figure 6-1: Ground on Either Side of Trace Area

6.9 Completing the Circuit path

The circuit path between the point at which the Transmitter signal couples to the conductor and where the Receiver is being held over the conductor has to be complete. Otherwise, very little Transmitter signal will reach the Receiver. If you suspect a break in the circuit path, look for disconnected leads, circuit breakers and open switches. It is essential to provide a good ground when setting up the Transmitter.

Power lines and telephone sheaths are assumed to be grounded. If the conductor is a pipe which has an insulated joint, such as a gas pipe with a meter, use the jumper cable (refer to Figure 4-2). Attach each end of the jumper cable on opposite sides of the insulator. (See Figure 6-1).

6.10 Common Bonded Conductors

Telephone, power, and CATV sometimes use a common ground bond. If other conductors are connected to your target conductor, putting a signal on the target can cause all the conductors to carry the same signal. This makes it difficult to identify the target conductor.

To verify you are tracing the targeted conductor, note the field strength and depth readings at a known location of the targeted conductor. As you trace, any change in field strength or depth reading should be gradual. If either reading changes abruptly, you are probably no longer over your targeted conductor.

6.11 Congested Areas

In an urban or otherwise congested locate area, it is not uncommon for water, gas, power, or telephone utilities to use common trenching. Every congested situation is different; there are too many variables for us to cover here. Use good judgment and locating skills to carefully determine where other conductors are in your locate area, and what effect they may be having on your tracing situation. Make use of comparison depth and field strength readings to determine and confirm that you are tracing your targeted conductor.

If you suspect that coupling from adjacent conductors is causing interference in the signal picked up by the Receiver, try increasing the strength of the signal received from the transmitter and decreasing the strength of signal from the interfering conductors by:

- 1 Changing to a different Transmitter coupling point or coupling mode.
- 2 Improving the grounding connection or moving the grounding point.
- 3 Determine the location of the adjacent conductors. Then check to be sure that neither the direct connect cable or the ground cable cross over any of the adjacent conductors. Re-position them if necessary.
- 4 If you are using the Inductive (Indirect) mode, you may be able to decrease the amount of interfering signal by changing the orientation of the Transmitter to the targeted conductor. Determine the location of the interfering conductor. Place the transmitter, turned on its end with the bottom facing the targeted conductor, over the interfering conductor as shown in Figure 6-2.

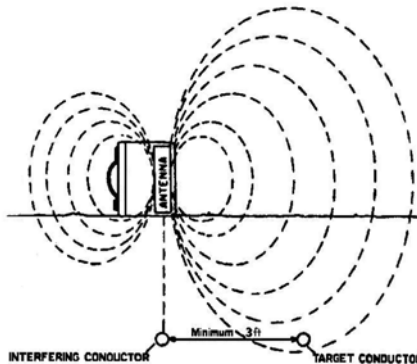

Figure 6-2: Position of Transmitter for Minimum Interference

6.12 Locating a Service Lateral

After you have traced the main, you may want to go back and locate the service laterals off the main. Service lateral traces are easiest to conduct in the Inductive Mode. Two operators are required for this procedure – Operator 1 remains stationary holding the Receiver as it to trace (Figure 4-5) over and parallel to the main. Operator 2, carrying the Transmitter (with the power on) and maintaining a minimum of 100 ft. between himself and the Receiver, walks parallel, but 5 feet from the main on the side, he expects to find the service laterals as shown in Figure 6-5. The field strength reading on the Receiver will increase as Operator 2 crosses over the service lateral with the Transmitter. Each time the field strength reading increases, Operator 1 signals Operator 2 and he/she marks the lateral location on the ground.

6.13 Valves, Manhole Covers, Tees and Risers

If the meter reading suddenly increases and then falls back while tracing a pipe, you have probably passed over a buried valve, manhole cover, tee, or riser.

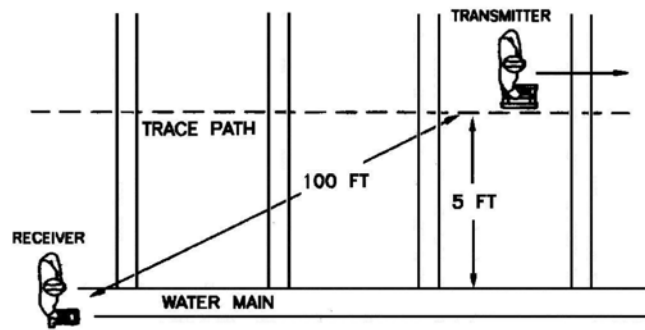

Figure 6-3: Locating Service Laterals

7 MAINTENANCE

7.1 810 Receiver Calibration

The centerline, signal strength, and depth of your 810 Receiver has been calibrated to factory specified tolerances. It is to your advantage to monitor the performance of your 810 Receiver on a weekly basis.

Metrotech recommends using a known conductor of which you know both the location and the depth to test your 810 Receiver, for example, a buried service lone at your work location. If the Receiver gives significantly different centerline, signal strength, or depth information from what you know to be true, it should be re-calibrated by Metrotech or a Metrotech-authorized Service Center.

7.2 Replacing the 810 Receiver Batteries

- 1 Have ready four 9 volt NEDA 1604, IEC 6LR61 (Int'l Std), or JIS6AM6 (Jpn Std) alkaline batteries.
- 2 Set the MODE SWITCH Receiver to the battery test position (second position).
- 3 In order for the Receiver to function properly, the needle must be to the right of the BATT STATUS line. The farther the needle is to the right of this line, the higher the charge in the batteries.
- 4 If the needle is to the left of the BATT STATUS line, the batteries need replacing. Turn the BATTERY ACCESS thumbscrew on the back of the Receiver. Replace all four cells, making sure that the batteries are installed with the positive (+) end to the positive terminals.
- 5 Close the battery access panel, ensuring that there are no wires caught between the Receiver body and the access panel. Make sure the latch is securely fastened.

7.3 Replacing the 810 Transmitter Batteries

Check the 810 Transmitter batteries by pressing the POWER TEST button. The indicator light will light up if the batteries are good. If you need to replace the batteries, follow the steps below:

- 1 Have ready six 1.5V Alkaline batteries, size D NEDA 13A, IEC LR20 (Int'l Std), or JIS AM1 (Jpn Std.).
- 2 Pull up on the Transmitter lid latch, open the Transmitter. Lift the battery cover plate off the batteries.
- 3 Remove the old batteries and replace with new ones, following the polarity orientation indicated on the label on the bottom of the battery cradle.
- 4 Replace the battery cover plate on top of the batteries, keeping the foam side up.
- 5 Close the Transmitter lid and secure the lid latch. The pressure of the circuit electronics attached to the lid of the Transmitter will maintain battery contact.

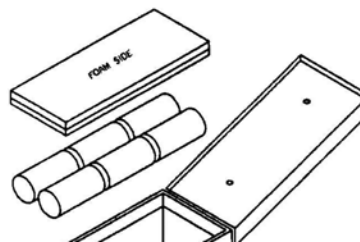

Figure 7-1: Replacing the 810 Transmitter Batteries

7.4 Metrotech Service Centers

If the equipment does not function properly, replace or recharge the batteries as described in the sections above. If the equipment still malfunctions, contact a Metrotech Service Center.

Metrotech Worldwide Headquarters

Western United States Service Center
 3251 Olcott Street,
 Santa Clara, CA 95054
 Service Tel: 1-800-638-7682 (U.S. and Canada only)
 Sales Tel: 1-800-446-3392 (U.S. and Canada only)
 Fax: 1-408-734-1415
 Email: service@metrotech.com; sales@metrotech.com
 Internet: www.metrotech.com

Metrotech Eastern United States Service Center

5211 Linbar Drive, Suite 503
 Nashville, TN 37211
 Toll Free: 800-624-6210
 Direct: 615-366-7323
 Fax: 615-360-9855
 Email: nashville@metrotech.com
 Web: www.metrotech.com/techsupport.asp

Metrotech European Service Center

Seba Dynatronic GmbH
 Dr.-Herbert-lann-Str. 6
 96148 Baunach, Germany
 Tel: +49-9544-680
 Fax: +49-9544-2273
 Email: service@sebadyn.de
 Internet: www.sebadyn.de

Additional Metrotech Instruments: Multiple and Dual Frequency Locators, Fiber Optic Cable Locating System, Pipe and Cable Locators, Magnetic Locators, Sheath Fault Locators, Leak Detectors, Valve Box Locators, 50/60Hz Detectors, and a variety of transmitting sondes and flexi-sondes.

COPYRIGHT NOTICE

The information contained in this document is for informational purposes only and is subject to change without notice. Metrotech Corporation makes no warranty of any kind with regard to the information contained in this manual, including but not limited to the implied warranties of merchantability and fitness for a particular purpose. Metrotech shall not be liable for errors contained herein, nor for incidental or consequential damages from the furnishing of this information.

This manual contains proprietary information that is protected by copyright. All rights are reserved. No part of this manual may be photocopied, reproduced, magnetically or electronically stored, transmitted, or translated into another language without the prior written consent of Metrotech Corporation.

© Metrotech Corporation 2008

DISCLAIMER

When hooking to live power via an inductive clamp, be certain clamp is connected around power line, not directly onto the power line. Please follow your own company's safety standards, and OSHA requirements.

WARRANTY

THERE ARE NO WARRANTIES, EXPRESSED OR IMPLIED, INCLUDING ANY WARRANTY OF MERCHANTABILITY, BEYOND THOSE STATED HEREIN.

Metrotech warrants its equipment to be free from defects in workmanship and material under normal and proper use and service for one year from date of purchase by original user. Metrotech assumes no obligation to repair or replace equipment which has been altered or repaired by other than a Metrotech-approved procedure, been subject to misuse, misapplication, improper maintenance, negligence, or accident; has had its serial number or any part thereof altered, defaced or removed; or been used with parts other than those approved by Metrotech. Warranty does not include batteries. Expendable items such as fuses and lamps are excluded.

Any detection product proved defective under this warranty will be repaired or replaced free of charge at the Metrotech Corporation factory or approved Metrotech repair station. The equipment should be returned to our factory by prepaid transportation after requesting and receiving return authorization from our Customer Service Department. Metrotech's obligations are limited to repair or replacement of broken or defective parts which have not been abused, misused, altered, or accidentally damaged, or at the option of Metrotech, to refund of the purchase price. Metrotech assumes no liability for removal or installation costs, consequential damages, or contingent expenses of any other nature.

Part #: 600A001-F

Price: \$5.00